

## Optimization for Remote Monitoring Terrestrial Petroleum Pipeline Cathode Protection System Using Graded Network

Pingting Liu<sup>1\*</sup>, Zhiyu Huang<sup>1</sup>, Shihong Duan<sup>2</sup>, Zikang Wang<sup>2</sup> and Jie He<sup>2</sup>

<sup>1</sup>College of Chemistry and Chemical Engineering, Southwest Petroleum University, Chengdu, 610500, China

<sup>2</sup>Department of Computer Science, University of Science and Technology Beijing, Beijing, 100083, China

\*iamlpt@126.com

### Abstract

*Method of cathode protection is employed to slow down the corrosion of terrestrial pipe. This paper aims to develop a system to monitor the terrestrial pipe cathode protection equipment to wholly track the operation status of buried pipe timely. The monitoring system integrates technology of wireless sensor networks, GPRS network and Internet not only to collect the cathode potential data in time and realize remote data transmission but also to regulate the guard mode of cathode protection on demand. Optimization mechanisms are adopted to effectively lower the energy assumption and to ensure data transmission reliability, from architecture design, selection of power saving hardware components, implementation of reliable network traffic mechanism including hierarchical network topology with least-complexity cluster head shift strategy, TDMA protocol with auto-adaptive resending scheme, work-on-duty with radio-awaken mechanism and so on. Trial running of the system has published good results with 96% or higher success ratio of data transmission, low power saving and power balance. In all, this system can meet the requirements of timely detecting physical malfunction of terrestrial pipeline and controlling field monitoring system on demand.*

**Keywords:** cathode protection; wireless sensor networks (WSNs); remote monitoring; web service; CF card

### 1. Application Scenario

Oil and natural gas pipelines always are laid under the surface of the ground which are easy to be eroded; usually cathode protection strategy are exploited to restrain anode reaction between protected unit and the medium based on electrochemical principles and to reduce the corrosion rate. Currently, potential information of cathode protection is measured by the underground test pile and can not be collected and transferred to the remote centre. So some failure with the cathode protection of underground pipeline can not always be found out and maintained on time.

Our target station with numbers of long-distance pipeline, covering an area of 10000 square meters, needs to be monitored in many positions, about 15m~35m apart from every two spots. Shown as Figure 1, cathode protection monitoring system periodically measures protection potentials and send data to remote control centre at least 20 km away.

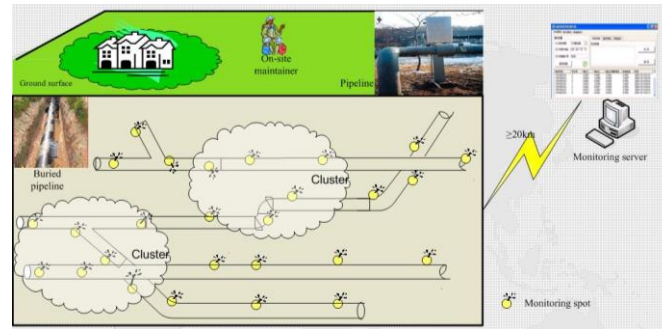

**Figure 1. Sketch of Plant Equipped with Pipeline Monitoring System**

The monitoring system is required to log the potential data of each monitoring spot one time every hour during the initial stage and then four times every day after three months. But if something wrong with the cathode protection devices, alarming data should transfer to monitoring centre in time with 5 minutes delay at most. Monitoring system also propagates polling command to sample specified potential information and control data to make system update running parameters.

System to monitor and control key cathode protection equipment needs to meet the following performance requirements:

(1) High reliability: most applications of monitoring equipment need to achieve higher data reception ratio (DRR), greater than 95%.

(2) Low cost: at the basis of the running and maintenance costs, the monitoring system should keep in operation during one to two years without human involvement.

To meet the function and efficiency requirements, this paper develops the monitoring system based on the wireless sensor networks due to the low cost [1] and Internet web service due to the convenient interface accessed at any time and any place according to the authority.

The first part of this paper gives an overview of monitoring system of pipe cathode protection. The second part summarizes current state-of-the-art of this kind of monitoring system and key technology adapted to wireless sensor networks. The third part introduces the structure of the monitoring system and design of all kinds of nodes. The fourth part makes an exposition of the design of network protocol. The fifth part analyzes the performance of the system.

## 2. Related Work

Cathode protection system plays an irreplaceable role in prolonging service life of petroleum and natural gas pipeline. The monitoring system as a secondary one can track the performance of cathode protection system on time. Presently on-site inspection by persons is still most common pipeline monitoring method [2], but this method with relatively high maintenance costs can not support full management of pipeline to find out the breakdown in cathode protection timely. The monitoring system proposed in this paper adopts graded network structure with WSN and Internet, which fully realizes pipeline inspection, accesses to the key running parameters with lower investment and lower cost.

Wireless sensor network technology has been widely employed in many industrial applications, including monitoring oil, gas and water pipeline. I. Jawhar proposed a framework of special line structure for pipeline infrastructure protection using wireless sensor networks to utilize communication reliability and security [3]. M. Rahman compared the ideas of detecting the pipeline leakage and proposed the early detection method of corrosion on buried pipeline using wireless sensor network as communication

media [4]. N. Mohamed summarized different sensor network architectures for monitoring underwater pipelines infrastructures and discussed three reliability factors of sensor networks [5]. But the said works focus on the long linear structure along pipe, unsuitable for detecting pipe malfunction in a station.

As we know, target monitored station is usually far away from monitoring centre, greater than 20 km. So it can assure supervisory with high reliability and low latency from Internet to choose right remote communication method. Digi Company [6] develops wireless connectivity products including long range solutions with maximum transmission distance of 40 miles and RF penetration by incorporating potent one-Watt transmission power with high receiver sensitivity in a proprietary Frequency Hopping Spread Spectrum (FHSS) radio. GPRS technology is also used to support delivering the information to the remote control centre for GPRS promises data rates from 56Kbps up to 114Kbps and continuous connection to the Internet for mobile phone and computer users based on the Global System for Mobile (GSM) communication and complements existing services such as circuit-switched cellular phone connections and the Short Message Service (SMS) [7].

There are many issues to be settled for putting wireless sensor networks into practical pipeline status detection. Firstly, wireless sensor nodes sensing ubiquitously usually are powered by battery due to cost constraints, so how to guarantee the node continuously work during 1 to 2 years lifespan is the primary key point. Secondly, monitoring centre should collect the status information on time with 95% DRR and be notified when alarming data arrives in time with 100% DRR. So it is important to ensure the data transmission reliability in harsh open country with interface of wind, rain and unexpected factors and non-connectivity for sleep scheme with synchronization deviation.

### **1) Research on low-power design of WSN**

The design of low power WSN is related to different aspects of sensor networks from hardware platforms to Mac protocols, routing and topology control [8]. Correctly choosing the hardware device included in platform can help saving power effectively. Sensor network lifetime can be significantly enhanced if the software of the system, including layered protocols, is designed in a way that lowers the consumption of energy. The major sources of energy waste in conventional MAC protocols are packet collisions, idle listening, overhearing, and overhead [9]. There are some general guidelines that one can follow to design a routing protocol which leads to energy conservation, such as avoiding link failures and packet losses which can lead to many retransmissions and subsequently higher power consumption. It also results into more energy conservation to partition network into clusters according topology control [10]. Multi-hop mechanism allows nodes to turn down emission power and reduce energy consumption of every transmission. In all, there are wide ranges of strategies for each part of the WSN which enhance the lift time of the network.

### **2) Research on reliability of WSN**

Wireless media is different from wired one bound in a protected environment. In the transmission process, many kinds of mishaps can come forth, such as signal attenuation, interruption, dispersion, multi-path delay, interference and frequency attenuation; meanwhile, nodes can enter into unexpected working mode, like hibernation, hided state and so on. The design and optimization of network protocol aiming to shield the influence factor of wireless transmission quality can improve the reliability. Reliable MAC protocols always apply retransmission mechanism to cut down packet loss rate. Reliable transport protocols can be further subdivided into upstream and downstream protocol [11]. Upstream refer to mostly unicast/convergecast transmission to sink nodes with typical reliable protocol of end-to-end ESRT[12](Event to Sink Reliable Transport) and hop-by-hop RMST[13] (Reliable Multi-Segment Transport), which can not resume from whole

packet loss. Downstream means mostly multicast/broadcast of code or configuration updates from sink nodes with typical example of hop-by-hop PSFQ[14] (Pump Slow Fetch Quickly) without congestion check. It is a well established fact that it is more energy-efficient to achieve reliability by hop-by-hop than by end-to-end.

### 3. System Framework

#### 3.1. Monitoring system of Graded Network

Station is most crucial operation unit carrying on pipe transportation. The target station in this paper shown in Figure 1 occupies 10000 square meters, where nodes are distributed 10~20m apart from each other. Cathode protection system of petroleum or natural gas pipeline usually is laid under the ground, about 2~3m away from terrestrial surface.

Solution for monitoring protection system in target station is a relatively high density WSN of 80 nodes. Management staffs supervise the station cathode protection system by Internet at any time. Graded network architecture shown as Figure 2 is employed in this paper to furnish the monitoring system framework. Clustered wireless sensor network is used to collect cathode protection potential data; communication subnet take responsibility for long-distance data transmission; and the Internet service network is responsible for data processing, analysis and system control.

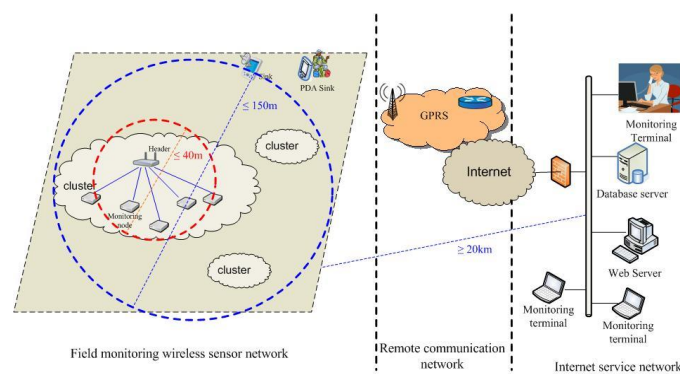

**Figure 2. Grade Network Structure of Monitoring System**

Many wireless technologies are used in remote communication as shown in Table 1. The monitoring system of cathode protection chooses GPRS network for remote communication, which has the merit of spread coverage, high data transmission rate, effective real-time processing, good correspondence quality, continued online and low expense. GPRS technology can support bi-direction long-distance data transmission by intercommunicating with the Internet following TCP/IP protocol; and high traffic capacity to satisfy the needs of sudden data transmission for so many sampling points.

**Table 1. Types of Wireless Remote Communication**

Communication Device	Transmission range	Ideal Transmission Rate
RF Module	1km ~ 40km	115 kbps
GSM/GPRS module	Range covered by base station	171.2kbps
Data radio	About 30km	19.2kbps

Monitoring system is constructed by following hardware components as shown in Table 2. Wireless sensor network (WSN) uses cluster scheme to realize energy conservation owing to good traffic quality and short communication range, which includes monitoring nodes and Sink nodes. Monitoring nodes, grouped into sensor node and cluster header, take charge of collecting working state of cathode protection system. There are two Sink nodes placed in the station as the gateway between station monitoring WSN and Internet to ensure connectivity with Sink node. Another kind of Sink integrated in PDA compatible with CF card can provide on-site maintenance by sending not only query command to wake up the monitoring node to collect information, but also control commands to adjust operating parameters of WSN. The web server in the Internet with a dynamic or static IP address communicate with Sink through GPRS network to collect potential information from WSN in time, check network working state and store data in the database server.

**Table 2. Hardware Components**

Subnet	Node	Node description
WSN	sensor node	monitoring the cathode protection potential data
	Cluster header	collecting the sampling data of whole cluster and transferring to Sink
	Sink node	assembling all sampling data of WSN and transferring data to monitoring centre
	PDA sink node	On-site maintenance
Internet	Database server	Storing the primitive data and analysis results
	Web Service server	Communicating with Sink and providing web service

### 3.2. Low Power Design of WSN Nodes

WSN nodes include monitoring nodes for potential collection and Sink node for data transfer. Monitoring nodes can be classified into sensor nodes and cluster header with same structure and different role. Headers, whose duty cycles are longer than sensor nodes, assume the responsibility of collecting data of whole cluster and uploading data to the Sink in addition to sampling the potential data. As a protocol converter between WSN and the Internet, Sink nodes need to send the acquired physical potential information to monitoring centre more than 20km away. Therefore, Sink nodes are equipped with extra device for long-distance communication besides hardware components included in monitoring nodes. A WSN node is designed with general structure shown in Figure 3(a) for numbered difference between nodes and convenient role configuration. Monitoring nodes are wired with pipeline inspection sensor through AD interface to acquire data and Sink runs on power from an electrical wall outlet. An actual WSN node is exhibited in Figure 3(b).

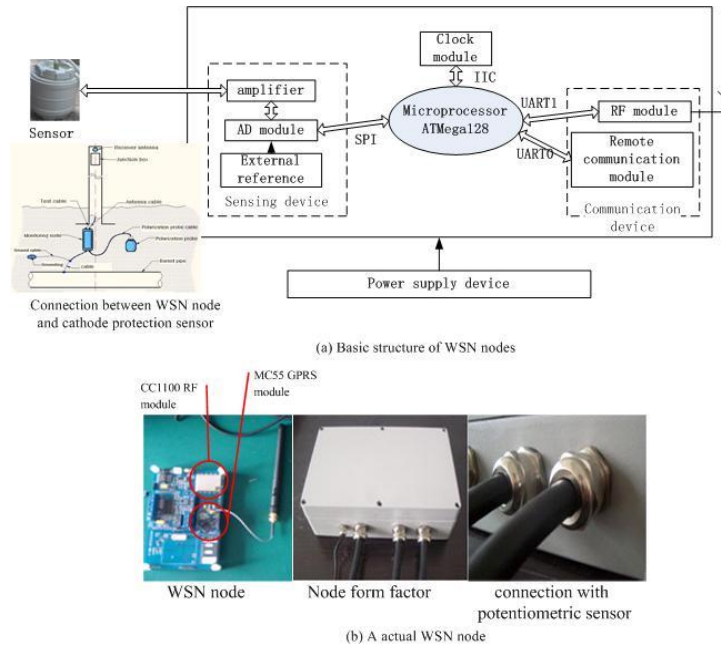

**Figure 3. Hardware Design of WSN Node**

### 1) Hardware platform for energy conservation

The four key devices in a WSN node are processing Unit, communication device, sensing device and power supply device. Choosing right hardware components with low power loss will affect the energy consumption. Hardware platform is designed following the energy-saving rules.

Principle of right-for-requirement. Device performance and energy consumption is usually inverse relationship; better computing performance will cause greater power consumption. Based on the desired performance level, ATmega128L from ATMEL Corporation is an ideal choose as processing unit, which is low-power CMOS 8-bit microprocessor with the advanced AVR RISC architecture [15]. Transceiver is used as communication component to transmit data between nodes. It is necessary for transceiver to support more diverse power level. Higher transmission power will result in higher SNR (signal to noise ratio), lower BER (bit error rate), and greater energy consumption. WSN nodes use CC1100 RF chip as a communication device. CC1100 has 23 levels of transmission power, from -20 dBm to +10 dBm.

Principle of work-on-duty. Monitoring system enters into sleep mode once it finishes work for long sample cycle. So hardware device should support rather low energy depletion in off-working state and energy consumption as lower as possible in working state. ATmega128L supports various operational modes with different energy consumption shown in Figure 4(a), RF module of CC1100 supports four status of TX, RX, idle and sleep mode shown in Figure 4(b), so it can utilize energy saving by adjusting the device's operating mode on demand and entering into sleep mode or power down mode in non-work stage.

It is important to consider the relationship between  $E_{saved}$ , energy saved during sleep period and  $E_{startup}$ , energy consumed in startup time. Clearly, switching to a sleep mode is only beneficial if the inequation exists.

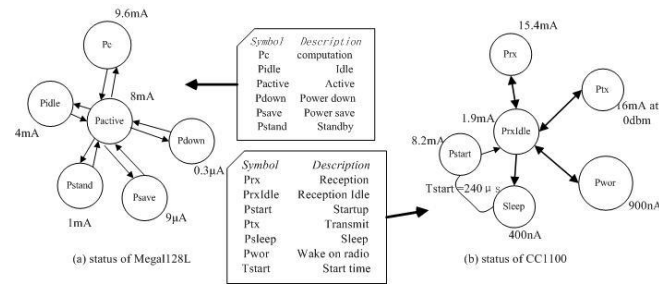

**Figure 4. Operational Modes in Typical Device**

$$E_{startup} < E_{saved} \quad (1)$$

$$E_{startup} = P_{start} \times T_{start} \quad (2)$$

$$E_{saved} = (PrxIdle - P_{sleep}) \times T_{sleep} \quad (3)$$

$T_{sleep}$  means duration of sleep stage.

There are two other devices to consume energy, sensing device in monitoring node and GPRS module in Sink node. Anko-TC series [16] of cathode protection probe are used as sensor to track polarization potential and corrosion potential of pipeline cathode protection system. Potential value ranges from -8v to +2v with higher sampling precision of 0.001V. ADS1211, a delta-sigma A/D convertor with high resolution of 24 bits, is selected as interface between sensor and node to meet the precision demand, whose power consumption in work state is 200mW. The output impedance of the electrochemical sensor is about 50MΩ, however, maximum input impedance of ADS1211 achieved in the gain mode of rate 1 is about 4MΩ. Direct connection of sensor device and ADS1211 will result in data error and instability. Therefore, an amplifier circuit is added to increase input impedance to ensure more accurate collection in case of different input voltage source. In this sensing device, OP27 is used as op amp, whose power consumption is about 500mW; and MAX6325 is selected as external reference, whose power consumption of is about 18mW. So the work energy of sensing device is rather high. MC55 module with smaller size and tri-band is used as GPRS module of WSN node. MC55 integrated with TCP/IP protocols stack provides voice and data transmission, network connections, SMS and fax function by the GPRS networks. Current of MC55 is 3.0 mA in sleep mode, 10.0 mA in idle mode, 100 µA in power-down mode, 300 mA in working state, and peak working current is 2.0A. GPRS module consumes high energy even if it enters into sleep mode. So both devices are designed to be powered on-demand by the control of a low dropout linear regulator (LDO). Quiescent current of LDO is very small to ensure tiny power consumption of node in non-work cycle.

## 2) Design of PDA Sink Nodes

PDA-style Sink nodes proposed in this paper provide maintainers to query operational states regularly on-site, which can send commands to wake up monitoring WSN collecting potential information of every sampling spot, and showing the practical performance in the PDA. PDA Sink nodes are integrated with model of Dell AXim X51 which has a CF card interface to expand storage. PDA Sink node with small size is compatible with CF card interface using a converter of OxCF950B between CF port and serial one. PDA Node is shown in Figure 5; (a) describes the architecture, (b) exhibits the entity and (c) shows the circuitry design.

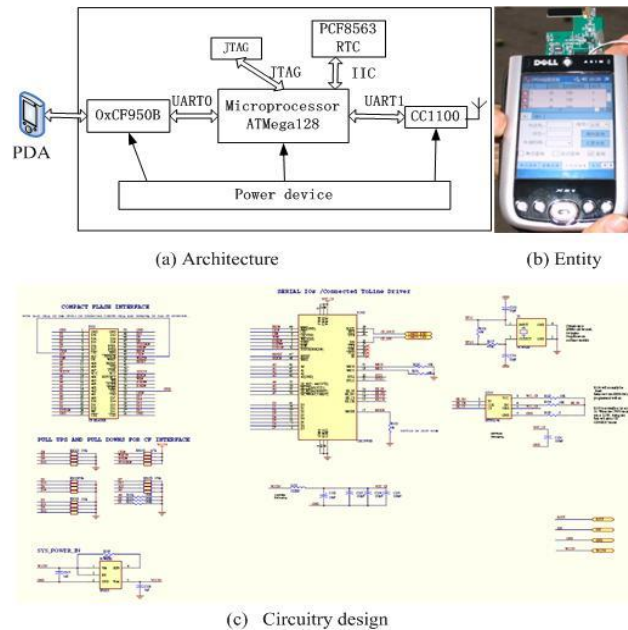

**Figure 5. PDA Sink Node**

## 4. Optimization for Reliable Network Protocol

Network protocol is designed to support the cathode protection monitoring system to achieve the following functions:

The monitoring nodes regularly transmit sampling information to monitoring centre, this process is called as upstream;

Monitoring centre send commands of adjusting working parameters or querying sensing data immediately to every monitoring node, this process is called as downstream;

The monitoring nodes report fault alarm to monitoring centre with delay of 5 minutes at most, this process is called alarm.

The system employs low duty cycle mechanism to cut down power consumption and to extend life cycle of network. However, data is transmitted in WSN by multi-hop, so how to ensure transmission reliability and report alarm in time is the key issue.

### 4.1. Network Topology

Cathode protection monitoring system provides data collection, remote transmission and control interface using graded network. According to data flow in network presented in Figure 6, an auto-adaptive WSN topology on demand shown in Figure 6 is proposed for data flow, reliability and energy balance.

(1) Due to so many nodes in station with high density, a clustered structure is adopted to avoid the collision;

(2) Nodes in cluster are in close proximity; each node exchange data directly with cluster header to form a star topology;

(3) Topology consisted of Sink node and cluster headers is self-regulated shown in shaded section of Figure 6. At first, each cluster header tries to exchange data with Sink directly with star shape. If first data transmission fails, other cluster headers try to transfer the resending data with mesh topology.



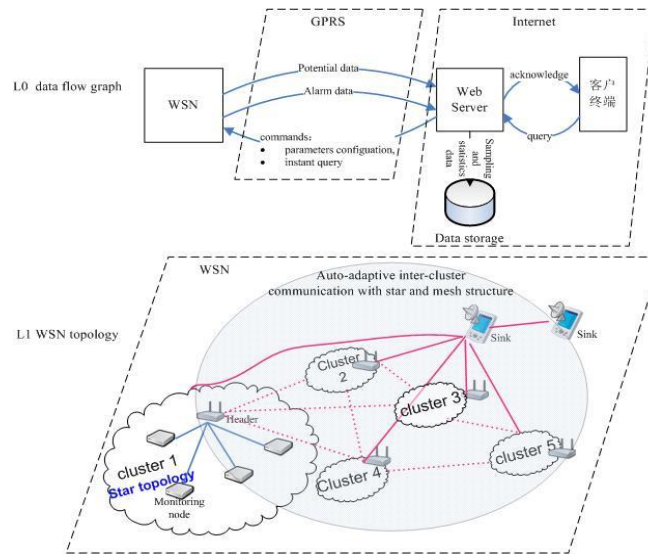

Figure 6. Data Flow and WSN Topology

## 4.2. Upstream Protocol

There are 5 clusters in WSN according to node placement. The header takes responsibility for gathering the electric potential information of all nodes periodically, and sending field information to the Sink node reliably as a member of Ad hoc network with other headers.

### 1) In-cluster Communication Protocol of TDMA with Minimum Complexity Header Shift Scheme

TDMA mechanism is usually employed to effectively reduce power loss by avoiding packet collisions and idle listening. In-cluster communication protocol is an optimized TDMA with self-configuration power resending method and minimum complexity header shift method. The range of CC1100, communication device, is high up to 300 meters. During in-cluster communication, nodes can lower sending power to cover closer extension of 40 meters or so. Lower power, shorter distance with less communication disturbance reduces effectively energy consumption. If one communication fails, monitoring nodes heighten power for reliable transmission in resending cycle. Cluster header undertakes gathering information from all nodes in same cluster. Longer work duration and multiple transmissions paid by header result in more energy consumption, so header shifts on demand of running status and longest life cycle of a cluster. The detail of in-cluster protocol is shown in Figure 7.

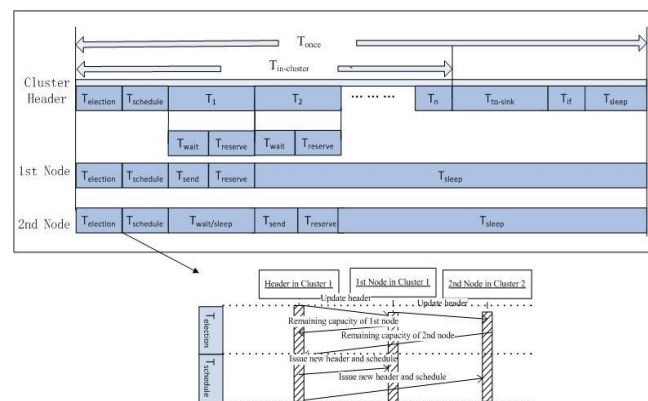

Figure 7. In-cluster Communication Protocol

Header is selected stochastically in initialization.

Header communicates with Sink node in  $T_{select}$ , and computes its own residual power to renew head shift flag in  $T_{if}$ . If shift flag is true, hibernation timer is set as  $T_{sleep}$ , or timer is set as  $T_{sleep}+T_{if}+T_{election}+T_{schedule}$ .

Header wakes up once timer is fired and checks the shift flag firstly. If flag value is true, header broadcasts wake-up data in  $T_{election}$ , then new header is elected according to remaindering power and node sequence. Old header sends new header number and schedule to nodes in  $T_{schedule}$ . Old header expropriates working time slot of new one, then all the nodes transfer data to new head one by one in their time slot.

$i$ th node will wake up in its working cycle  $T_{send}$ , but if header is renewed,  $i$ th node will be awakened before timer is fired to update its working schedule.  $i$ th node transfers data to header in  $T_{send}$ , meanwhile, header set delay timer of  $T_{wait}$ , if header cannot receive data from  $i$ th node in  $T_{wait}$ , header will increase sending power to ask  $i$ th node adjust power and resend data in  $T_{reserve}$ . Retransmission mechanism ensures data reliability.

$i$ th node enters into sleep state when it finishes data transmission; however, header needs to collect sampling data from all the members in its cluster, then it switches to process (2).

## 2) Inter-cluster auto-adaptive communication protocol of integration of TDMA and CSMA

Header communicates to Sink node in  $T_{tosink}$  to implement data fusion and transfer all sampling data. Sink node is furnished in workshop of station and can be fed by wall outlet power, so it can work always to connect remote control centre at any time. Inter-cluster communication protocol integrates the TDMA and CSMA mechanism and auto-adaptive switch mode to support dynamic topology alteration. The detail of protocol is shown in Figure 8.

(1) Headers use TDMA mechanism in  $T_{1p}$  to transfer its group data to the Sink and receive the ACK message. Header adjusts its own sending power in  $T_{1p}$  to extend coverage up to 200 meters. Usually, data can be directly transferred to the Sink, same with working process of 1st cluster header. So, Sink and all the heads constitute the start topology network.

(2) In order to guarantee the data reliability of transmission, ACK mechanism is employed. If some header has not received any ACK from Sink in scheduled time, it will resend data in carrying reproduction flag. In  $T_{2p}$ , CSMA protocol is used, and other header will help to forward resending data heard to the Sink node once it finds out reproduction flag.

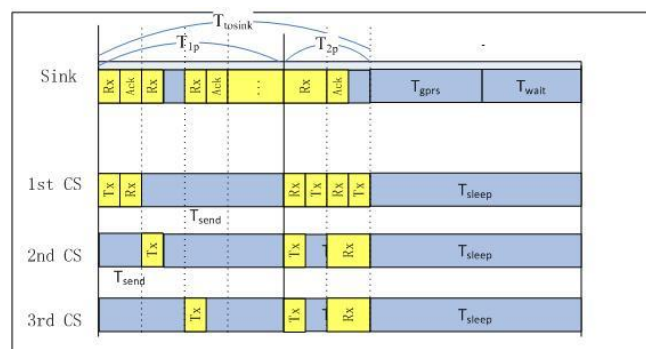

Figure 8. Inter-cluster Communication Protocol

### 4.3. Downstream Protocol

Monitoring system is a two-way system. Monitoring centre issues commands on demand for adjusting parameter or querying WSN to gather cathode protection system performance information. Sink node communicates with centre using GPRS network and short-term connection mechanisms; the connection is established to transfer data, and is cut when data traffic is over. The Sink is not often in Internet, and IP address is dynamic. So the control centre issues commands to the Sink by SMS message; the Sink periodically check the new arrival message and analyze the commands.

(1) If the command is to query cathode protection system instantly, the Sink awakens neighbouring nodes using CC1100 RF module by radio-awake mechanism. Each node transfers command once to wake up all the monitoring nodes from near to far. Each node works following the steps described in Figure 7 in accordance with the last schedule without reselecting header. Header collects all the data and transfers to the Sink; then header enters into Tif stage to confirm whether to shift header or not.

(2) If the command is to modify the operating parameters. The Sink sets update flag and send ACK package carrying correction command with timestamp in the next work cycle of WSN. Each header picks up correction command, and forwards the data to the sensor nodes using extended ACK integrated with correction information in TDMA ACK slots. In the next work cycle, sensor nodes will return flag of completing modification in data package, so headers and the Sink decide whether to resend correction data hierarchically.

### 4.4. Optimization for Network Reliability

The monitoring centre is PC machine in the Internet, which can exchange data with Sink node using TCP protocol based on the GPRS technology. Regular sampling data are transferred to monitoring centre as upstream data with long cycle. However, alarm data should be reported in time. So, monitoring system opens a special data path to allow alarm uploading. Each sensor node tries to check the potential data every 2 minutes; if abnormality arises, sensor node applies to wake up its header, header wakes up all other header and transfers the alarm to the Sink with the same work process in T2p shown in Figure 8. The Sink sends the alarm to remote centre in Tgprs. ACK scheme and resending method are employed in every step to assure data transmission of 100% success ratio.

Low-duty-cycle work mode effectively reduces energy consumption, but increase the risk of non-connectivity. So the whole WSN needs to achieve time synchronization with monitoring centre. Sink node regularly sends synchronization request to obtain the absolute time and update WSN RTC time with same steps of processing command to modify the operating parameters.

## 5. Performance Analysis

System accomplished in this paper has been laid in a station of some petroleum company to start pilot run, which collects sampling data once every an hour. Figure 9 shows the monitoring interface accessed by IE with operation data from February to May in 2010.



Figure 9. Interface of Monitoring Centre

Based on the analysis of information collected by monitoring centre located in Xiaotang Hill of Beijing, performance of network reliability and energy consumption can meet the requirements.

### 5.1. Performance Analysis in Practical Application

This paper summarizes sampling data covering 3 months pilot operation, which carry with voltage information of each monitoring node gathered by one of AD port. Figure 10 shows analysis chart of energy consumption and transmission reliability. We can come to the conclusion that system reliability of data acquisition and transmission reaches above 96%. At present the longest delay time of upstream data is 5 minutes, the primary factor of time-consuming lies in the GPRS communication. Furthermore, energy consumption of different clusters is well balanced for average voltage change of each cluster is basically same.

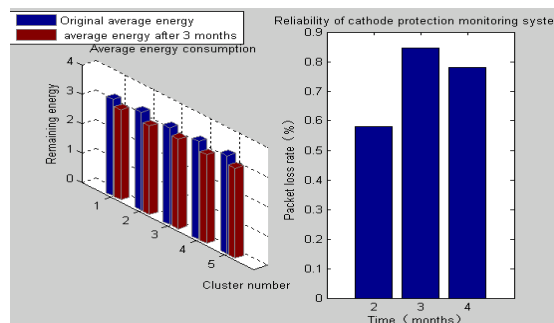

Figure 10. Performance Analysis of Practical Application

### 5.2. Performance Analysis with Simulation

Alarm information is required to be published in time. In order to verify the performance of alarm report mechanism, program in the monitoring node reserves an interface to simulate generating the alarm data according to test command from monitoring centre. Four nodes in each cluster are specified to sampling fake alarm data, and upload the alarm to monitoring centre along the alarm path. The average transmission time lag is 4.46s mainly for delay mode used in GPRS module to wait for effective state acknowledge.

WSN nodes powered by battery in monitoring system fits for collection and transmission of cathode protection potential in the station. Clustered structure and header shift mechanism is one of key power management. This paper simulates the work of WSN in the monitoring system energy consumption model of key components described in

Section 3.2 based on OMNet++ [17] to compare the result of different shift cycle of every upstream and every day. Shift process spends extra power, and timely header shift balances energy consumption of nodes in the same cluster. Figure 11 describes the running results of simulation and comparison of different shift cycle. We can draw the conclusion of every day shift is some better than shift after every upstream transmission.

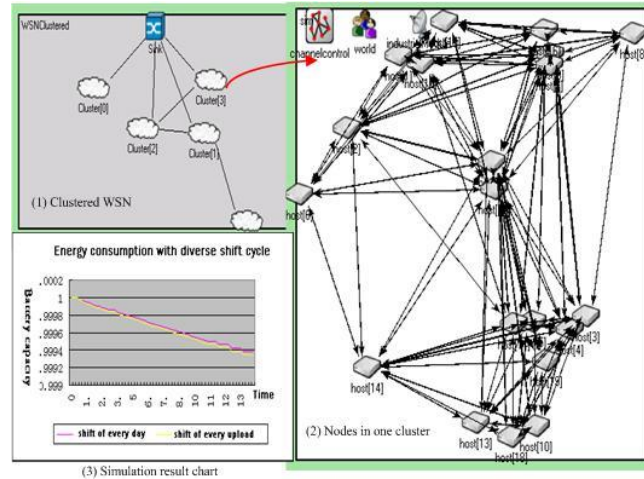

**Figure 11. Energy Consumption with Shift of Every Upstream Transmission and Every Day**

## 6. Conclusion

Cathode protection monitoring system accomplished in this paper demonstrates a solution for protecting long distance transportation pipeline for a long-term. This system integrates three kinds of networks, WSN monitors pipeline's electric potential information, the GPRS network is responsible for the long-distance transmission, Internet is in charge of issuing and analyzing monitoring information. Practical running data of this system optimized with reliable transmission protocol and energy saving mechanism indicate monitoring system can meet requirement of tracking status of cathode protection system in station. Further optimization will be introduced for reducing the transmission delay.

## Acknowledgements

The authors also acknowledge the support from the National Natural Science Foundation of China No. 61302065, No. 61304257 and Beijing Natural Science Foundation project No.4152036.

## References

- [1] Yu H., Li Ou, Zhang X. Wireless sensor networks theory, technique and implementation. National Defense Industry Press, Beijing, 9 (2008).
- [2] SUN Ren-xing. Evaluation of Sacrificial Anode Cathodic Protection of Steel Pipe Piles of a Wharf in Zhoushan. Corrosion & Protection, 12 (2009).
- [3] I. Jawhar, N. Mohamed, and K. Shuaib. A Framework for Pipeline Infrastructure Monitoring Using Wireless Sensor Networks. The Sixth Annual Wireless Telecommunications Symposium. IEEE Communication Society/ACM Sigmobase, Pomona, California, U.S.A., April (2007).
- [4] M. Rahman, H. Hasbullah. Early detection method of corrosion on buried steel gas pipeline using wireless sensor network. Computer and Automation Engineering (ICCAE), 2010 The 2nd International Conference, Singapore, Feb (2010).
- [5] N. Mohamed, I. Jawhar, J. Al-Jaroodi, Liren Zhang. Monitoring Underwater Pipelines Using Sensor Networks. High Performance Computing and Communications (HPCC). 2010 The 12th IEEE International Conference, Melbourne, VIC, Sept (2010).
- [6] <http://www.digi.com>

- [7] YanRu Xue, Min Liu. Design and Implementation of Wireless FAEM System Based on the ZigBee and GPRS. 2010 International Conference on Electrical and Control Engineering, Wuhan, China, June (2010).
- [8] Bahareh Gholamzadeh, Hooman Nabovati. Concepts for Designing Low Power Wireless Sensor Network.
- [9] Kazem Sohraby, Daniel Minoli, and Taieb Znati. Wireless sensor networks: technology, protocols, and applications. John Wiley & Sons, 75-229 (2007).
- [10] A. Swami, Q.Zhao, Y.W.Hong, and L.Tong. Wireless sensor networks: signal processing and communications perspectives. John Wiley & Sons, 69-344 (2007).
- [11] P. R. Pereira, A. Grilo, F. Rocha, M. S. Nunes, A. Casaca, C.Chaudet, P. Almstrom and M. Johansson. End-to-end reliability in Wireless Sensor Networks: survey and research challenges. EuroFGI Workshop on IP QoS and Traffic Control, Lisbon. December (2007).
- [12] Sankarasubramaniam, Y. Akan, O.B. and Akyildiz, I. F. ESRT: Event-to-sink Reliable Transport in Wireless Sensor Networks. Proceedings of the ACM MobiHoc 03. June 2003, Annapolis, Maryland, USA, 177-188 (2003).
- [13] Stann, F. and Heidemann, J. RMST: Reliable Data Transport in Sensor Networks. 1st IEEE International Workshop on Sensor Net Protocols and Applications. May 2003, Anchorage, Alaska, USA, 1-11(2003).
- [14] Wan, C.Y. Campbell, A.T. and Krishnamurthy, L. PSFQ: A Reliable Transport Protocol for Wireless Sensor Networks. WSNA'02, September 2002, Atlanta, Georgia, USA, 1-11 (2002).
- [15] ATMEL.8-bit Microcontroller with 128K Bytes In-System Programmable Flash. [http://www.atmel.com/dyn/resources/prod\\_documents/doc2467.pdf](http://www.atmel.com/dyn/resources/prod_documents/doc2467.pdf), (2009).
- [16] <http://www.ankopipe.com>
- [17] Omnetpp. Available at: <http://www.omnetpp.or>