

Design and Analysis of an Automatic Voltage Regulator Microcontroller-based Distributed Power Supply

Xiumin Wang^a, Liting Jiang^a, Liang Shan^a, Zhengquan Li^{a,b}, Rihui Xiong^a and
Jianbing Xu^c

^a *China Jiliang University, College of Information Engineering, Hangzhou
310018, China*

^b *Southeast University National Mobile Communications Research Laboratory,
Nanjing 210000, China*

^c *Shine Light Technology Co., Ltd, Hangzhou 311121, China
wxm6341@163.com, Lzq722@sina.com, Xu_jianbing@163.com*

Abstract

The design of an automatic voltage regulator (AVR) microcontroller-based distributed DC power supply is presented. The system includes a photovoltaic (PV) power generation, commercial hardware drive power system, and a battery booster circuit. A software control technology is used for storage battery charging and discharging. The PID control algorithm is used to control AVR microcontroller to achieve maximum power point tracking (MPPT) and to improve system stability. In addition to the traditional battery power, the system can make full use of solar system for energy sustainability. Experiment results show that the proposed system outperforms the traditional system with respect to the function of track, monitor and fine-tune for system steady state.

Keywords: AVR, PID algorithm, MPPT, Battery charging, PV.

1. Introduction

With continuous development of electronic power devices, microprocessor power system is widely used in numerical control systems. Distributed power supply technology is one of the development trends of modular power supply system. Traditional distributed power supply uses AC-DC module to transform commercial voltage into DC bus voltage transferred to load [1]. For power commercial voltage this control method produces greater energy consumption. The current electric power crisis and large area blackout have exposed that the centralized traditional power system can't meet the requirements for modern digital developments [2]. We introduce microcontroller acquisition technology and AVR control software system into the traditional distributed power supply design for improved system performance. The various relay switch circuits are controlled by selecting power modes in different environment to reduce the utilization of commercial power. We use PID algorithm to realize the function of MPPT and to adjust the stability of output power parameters. The optimization of battery charging process is optimized to reduce the interference of output voltage.

2. Proposed Distributed Power System

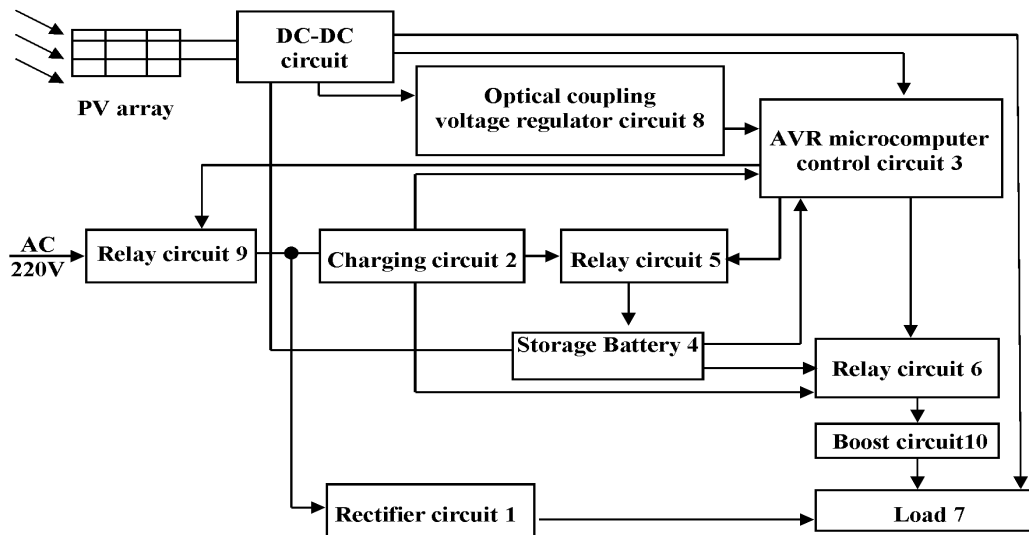

Figure 1. Proposed Distributed Power System

3. Description of Software Control Circuit

The system uses mega88 chip as one of the core control circuits to realize the communication between PCs. Mega88 has advanced instruction sets and single period which makes the rate of data sending and sampling fast. 74HC595 is used to be compatible with the low level TTL (transistor-transistor logic) which is transformed by AVR microcomputer to PC [4]. Figure 2 shows the AVR software control circuit.

The MAX485 chip has input receiver DI and output driver RO. Output driver RO and input receiver DI respectively connect serial port RXD and data port TXD. \overline{RE} is the signal receiving enabling port and DE is signal sending enabling port. Device accepts battery sampling signal when \overline{RE} is in low level. Device sends battery charge and discharge signals when DE is in high level. Battery charge and discharge voltage can be directly observed on digitron when the sampling voltage is converted to digital signal by A/D system [5]. We used interruption mode to complete A/D conversion. The control program utilizes method of query output. Microcontroller (8MHz) interrupt mode is written in C language.

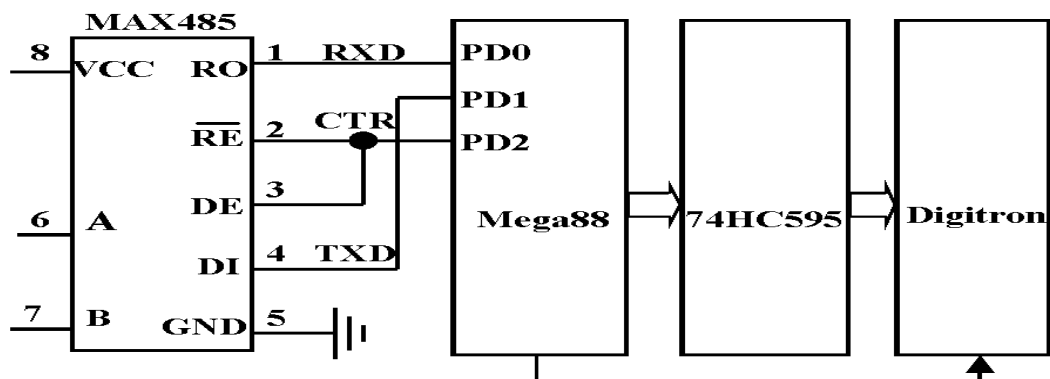

Figure 2. Software Control Circuit

4. Description of PID Algorithm Voltage Control

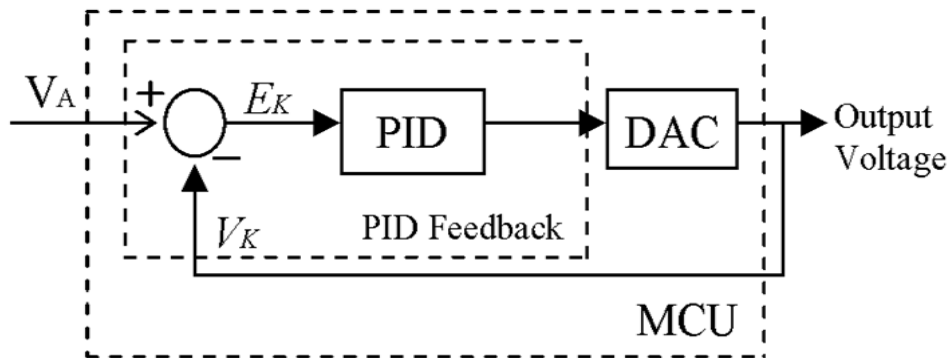

Figure 3. PID Control Principle

PID controller is widely used because of its availability and simplicity [6]. Figure 3 shows the PID control system. The output power can be reflected by the feedback sampling voltage, so the feedback voltage V_k is achieved by MCU. We develop PID algorithm to track the transient response characteristics between output voltage V_k (k Time) and reference voltage V_A (220V). It can balance energy supply between battery power and commercial power.

We defined $E_k = V_A - V_k$ and $\Delta V = E_k - E_{k-1}$ in MCU program. The system regulates the output voltage to $V_{k+1} = V_k + \Delta V$ when $\Delta V \cdot E_k > 0$. Output voltage will be adjusted to $V_{k+1} = V_k - \Delta V$ when $\Delta V \cdot E_k < 0$. Output voltage is $V_{k+1} = V_k$ when $E_k = 0$. Fig.4 shows the PID algorithm flow chart. The PV power system is discussed next.

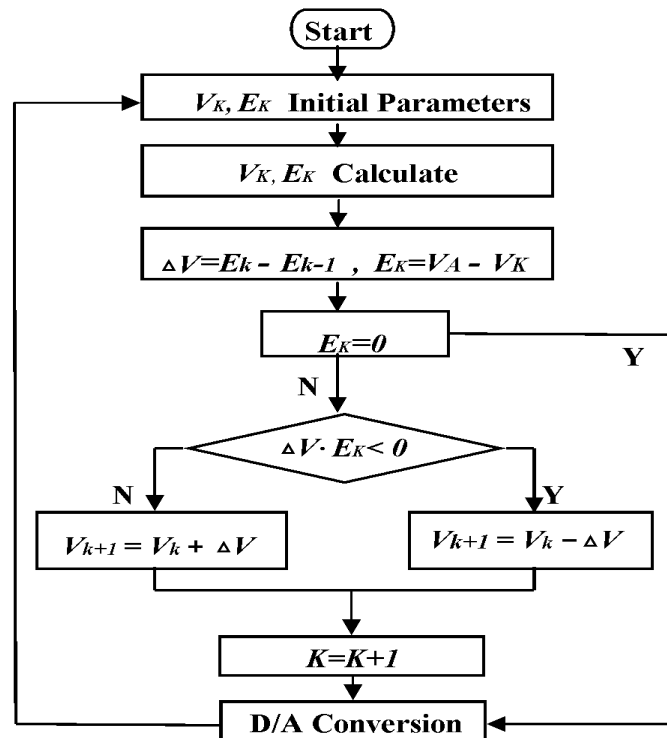

Figure 4. Flow Chart of PID Control Algorithm

5. PV Power System

Solar energy is considered as green ecological energy which has advantage of high efficiency. PV arrays are the core components of PV power system. As the volt-ampere characteristic of PV array has a strong nonlinear characteristic that is affected by illumination and temperature. This characteristic affects the solar maximum power output because the impedance of solar cells does not match load equivalent resistance [7]. We use MPPT technology to make solar battery works in the maximum power point and to improve the efficiency of PV power system. MPPT is an important technology in independent PV power system. This technology can control the voltage of solar cell output stability. PV arrays work in maximum power point and make full use of solar energy. The disturbance observation method is widely used in MPPT technology because of simplicity and reliability. The method is continuing to detect the output parameters of solar cell according to varying output power.

5.1. DC - DC Converter Application

As PV system is easily affected by light intensity, DC-DC converter is used to realize the dynamic load change to achieve maximum power output. Figure 5 shows the circuit of DC-DC converter with MPPT control [8]. DC-DC converter adjusts output voltage as well as current. AVR microcontroller analyzes the measured data of DC-DC converter in the PV arrays circuit. The microcontroller outputs PWM pulse to adjust the duty ratio of DC-DC converter which is used to control the solar cell output. If transformation working point and the maximum power point of PV arrays overlap, load equivalent resistance can match PV cells impedance to make full use of solar energy.

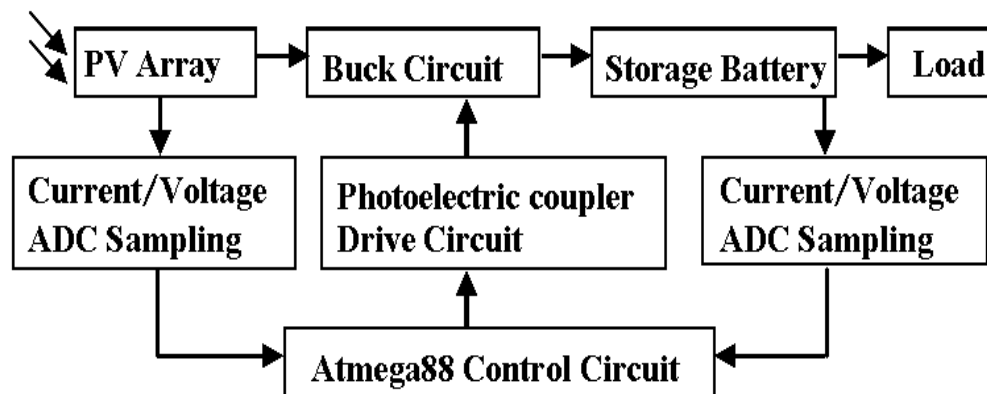

Figure 5. MPPT Circuit of DC-DC Converter

5.2. Battery Charging Mode

Independent PV power system uses PV arrays to charge the battery. Lead-acid battery is one of the weakest links as energy storage module in the system. The charging method affects the service life of the lead-acid battery. The system optimizes the battery charging process by detecting the output parameters of PV cell and charging battery [9]. Fig.6 shows the three phase optimization ways of battery charging. In the process of constant current charging (stage 1), charging current is constant when the charging voltage increases linearly. In the process of constant voltage charging (stage 2), the charging current drops gradually with the increase of battery electromotive force. In the process of float voltage charging (stage 3), the charging current is almost zero to improve the charging efficiency.

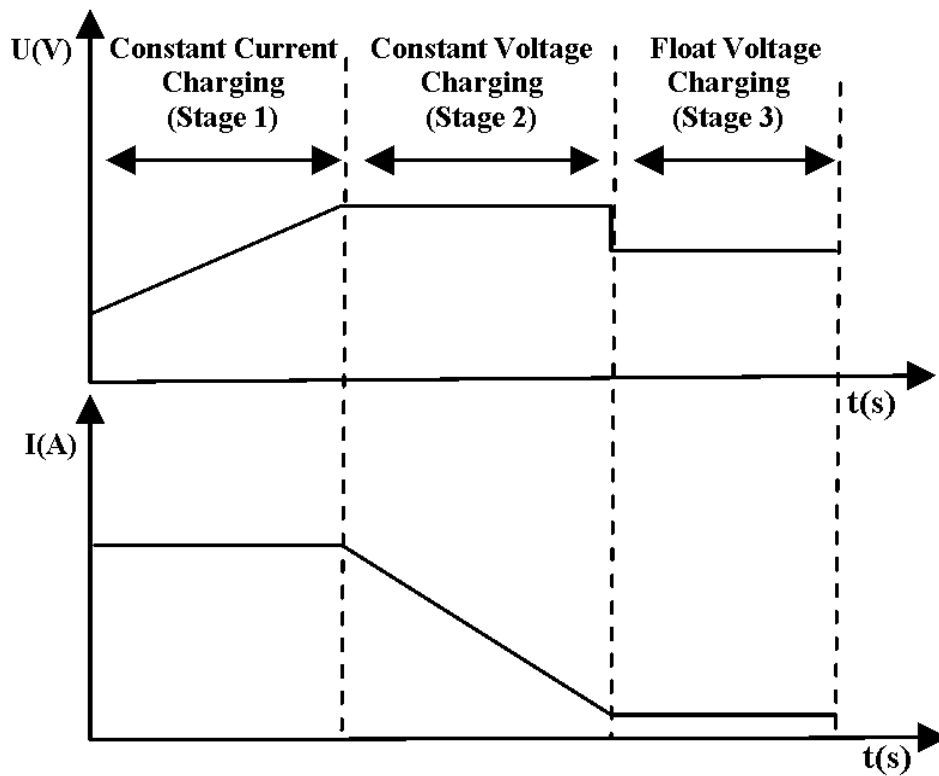

Figure 6. Optimized Approach of Battery Charging

5.3. PWM Method

Figure 7 shows the MPPT control method with PID algorithm. Voltage and current of PV arrays are sampled by AVR system. Output power of PV arrays is calculated by multiplier in AVR system. Then current power value is compared with the memory power value by comparator to adjust the duty cycle of charging PWM. We analyze the output characteristics of PV arrays and battery charging. Charging PWM controller of PV power system is designed based on AVR processor. Software system uses atmega88 chip as a core controller of buck DC-DC conversion circuit. Control program analyzes the parameters signal of solar cell by AD sampling to produce PWM signal for battery charging. Photoelectric coupler driver circuit can adjust switch tube turn-on time of buck circuit. Output parameters of PV cell are sampled by AVR microcontroller to calculate the values of PID feedback. AVR microcontroller program continuously collects varying duty ratio of PWM to track the direction of maximum power point. Thus the photoelectric coupler driver circuit can precisely change the duty ratio size until program finds the maximum power point. Battery charging signals are still collected to meet the load changing impedance. The controller utilizes MPPT method to improve the efficiency of battery charging.

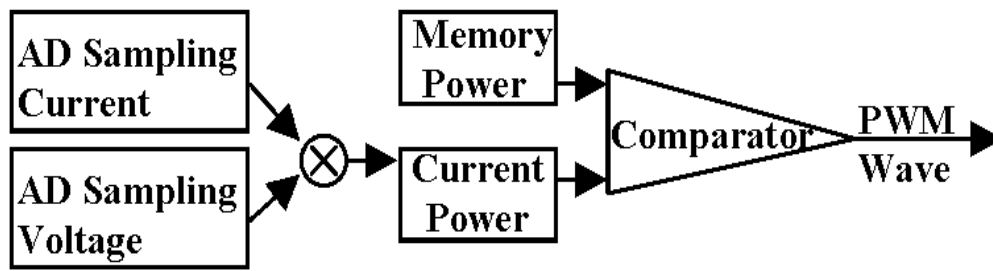

Figure 7. MPPT Method with PID Algorithm

6. Results and Discussion

In this section we present both experimental and MATLAB simulation results. In Figure 8 the Channel R1 and Channel 1 show the commercial voltage and battery voltage, respectively. The AVR microcontroller program disconnects the commercial power system to make battery voltage automatically boost up to 220V for load working when battery is fully charged. We observe that the commercial power supply turn off at point 'a' and the battery storage power supply turn on within 150ms. The dynamic response of system output voltage is stable. As shown in Figure 9, the minimum voltage is 214.2V and maximum voltage is 228.7V indicating that the small fluctuation occurs at around 220V. The system achieves the maximum output voltage about 1.4 sec earlier than the non-PID algorithm (dashed line shows simulation result for Non-PID algorithm). The minimum and maximum voltages are 210.7V and 242V, respectively. Experiment results show that the proposed system outperforms than the traditional system with respect to the system steady state.

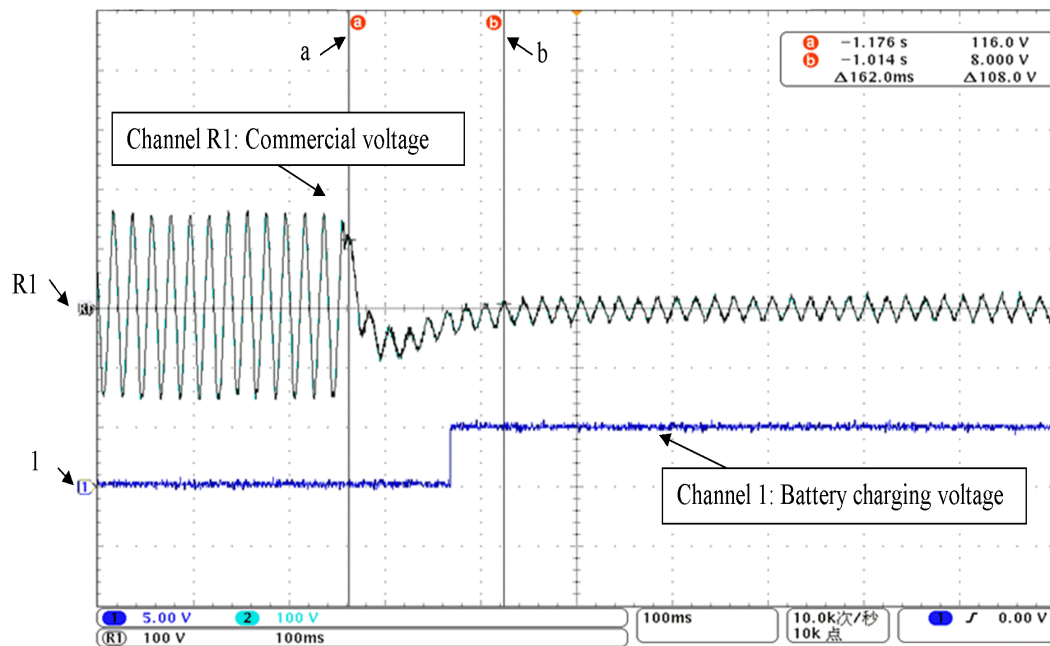

Figure 8. Battery Charging and Commercial Switching Waveforms

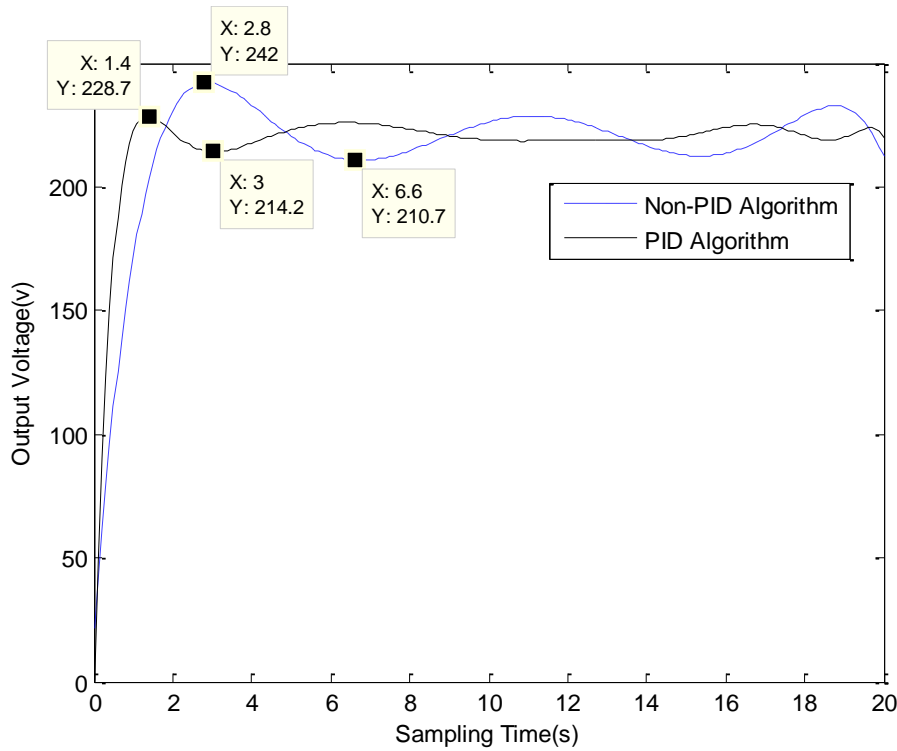

Figure 9. PID Algorithm Simulation Comparison Chart

Table 1. Main Parameters of Distributed Power System

Solar Parameters		Battery Parameters		Power System Parameters	
PV Open Voltage	24V	Output Voltage	12V	PWM Frequency	50KHz
PV Short Current	5.5A	Constant Charging Voltage	14.2V	Charging Capacitance	98%
Highest Power Voltage	18V	Floating Charging Voltage	13.8V	Drive Efficiency	98.5%
Load Resistance	2Ω	Maximum Charging Current	2A	MPPT Efficiency	94%
Reference Temperature	25°C	Battery Capacity	60Ah	Temperature Range	-20~70°C

Table 1 shows main parameters of the proposed distributed power supply system. The battery charging capacity is 98% which is 1% higher than the traditional power supply reported in the literature [10]. Similarly, the MPPT efficiency is about 94% which is 2% higher than the existing work reported in the literature [11]. It improves the use efficiency of solar energy and optimizes the charging process of battery charging.

Table 2. Charging Battery Parameters of Boost Circuit with MPPT

Comparison Object	Non-MPPT Technology			MPPT Technology		
Boost Circuit Load (Ω)	200	195	190	200	195	190
Output Voltage (V)	11.85	11.81	11.79	11.95	11.89	11.86
Output Current (A)	1.71	1.74	1.79	1.91	1.93	1.96
Output Power (w)	20.26	20.54	21.10	22.82	22.95	23.24
Output Efficiency (%)	84.43%	85.58%	87.79%	95.08%	95.60%	96.86%

Table 2 shows the charging battery parameters of boost circuit with MPPT method. The utilization efficiency of charging power to load with MPPT technology is obviously improved that is verified from comparative data in table 2. The average output power efficiency of charging battery with MPPT method is about 96%.

Table 3. Parameters Comparison Data

Comparison Object	[10]	[11]	Proposed work
Control Method	PI	--	PID
Microchip	PIC16F877A	SG3524N	ATMEGA88
Converter Circuit	buck	buck-boost	buck
Switching Frequency	20KHz	72KHz	50KHz
Battery Charging Signal	PWM	PWM	PWM
Charging Capacitance	97%	--	98%
MPPT Efficiency	--	92%	94%
Load Average Efficiency	--	--	96%

Table 3 compares our results with the existing works (References 10 and 11). We can observe that the proposed system performed better with respect to the charging capacitance and MPPT efficiency.

7. Conclusions

An AVR microcontroller-based distributed power system has been designed and reported in this paper. The system includes hardware driving system and AVR microcontroller system. We use software control technology for storage battery charging and discharging. The various relay switch circuits are used to control power modes in different environments. Experiment results show that the proposed system outperforms the traditional system with respect to the function of track, monitor and fine-tune for system steady state. The output voltage is almost 220V. The system achieved quick stability (1.5 sec earlier than the Non-PID algorithm). Battery charging efficiency is about 98%, MPPT efficiency is 94% and the average output power efficiency is 96%, indicating that the proposed system performed better than the traditional system.

Acknowledgements

This work was supported in part by 2013 National Natural Science Foundation of China under Grant (No. 61379027), National Natural Science Foundation of China under Grant (No. 51404223) and the Open Research Fund of National Mobile Communications Research Laboratory of Southeast University (No. 2011D18). We would like to thank anonymous referees for their constructive comments.

References

- [1] S. Tachikawa, T. Hirose, H. Yanagi, Y. Ishizuka and H. Matsuo, "An analysis of a constant current controlled bi-directional dc-dc converter with digital control", The 31st International IEEE Telecommunications Energy Conference, (2009); Incheon, Korea.
- [2] M. Saghaleini, A. Hekmati and S. Farhangi, "An advanced distributed power supply for power electronic transformers", The 33rd Annual Industrial Electronics Society Annual Conference, (2007); Taipei, China.
- [3] K. Yoshida, M. Kamruzzaman, F. A. Jewel and R. F. Sajal, "Design and implementation of a machine vision based but low cost stand alone system for real time counterfeit bangladeshi bank notes detection", The 10th Computer and Information Technology Conference, (2007); Dhaka, Bangladesh.
- [4] A. B. Tambuwal, R. M. Noor and O. Michael, "Improvement of DSR routing protocol using TTL-based

- scheme in mobile ad hoc networks”, IEEE RFID-Technologies and Applications Conference, (2013); Johor Bahru, Malaysia.
- [5] Y. C. Ding and J. Y. Guo, “LED display screen design and Proteus simulation based on single-chip microcomputer”, The 2nd IEEE Information Engineering and Computer Science Conference, (2010); Wuhan, China.
- [6] F. W. Cao and Y. W. Wang, “Design of fuzzy PID control algorithm for series resonant inverter power supply based on DSP”, IEEE Computer Application and System Modeling Conference, (2010); Taiyuan, China.
- [7] P. Sharma, B. Patnaik, S. P. Duttagupta and V. Agarwal, “Dynamic power optimization of contoured flexible PV arrays under non-uniform illumination conditions”, 35th IEEE Photovoltaic Specialists Conference, (2010); Honolulu, America.
- [8] M. B. Shadmand, M. Mosa, R. S. Balog and H. A. Rub, “An improved MPPT technique for high gain DC-DC converter using model predictive control for photovoltaic applications”, IEEE Applied Power Electronics Conference and Exposition, (2014); Fort Worth, America.
- [9] H. R. Teymour, D. Sutanto, K. M. Muttaqi and P. Chufo, “Solar PV and battery storage integration using a new configuration of a three-level NPC inverter with advanced control strategy”, IEEE Transactions on Energy Conversion, vol. 29, no. 2, (2014), pp. 354-365.
- [10] S. C. Zheng and L. Y. Wang, “Research on charging control for battery in photovoltaic system”, The 6th IEEE Industrial Electronics and Applications Conference, (2011); Beijing, China.
- [11] L. An and D. Lu, “Design of a single-switch DC/DC converter for a PV-battery powered pump system with PFM+PWM control”, IEEE Transactions on Industrial Electronics, vol. 62, no. 99, (2014), pp.910-921.
- [12] J. Y. Wu, W. J. Li, J. P. Huang, J. L. Zhang and D. R. Chen, “Key techniques for Mobile Internet: a survey”, Scientia Sinica Informationis, vol. 45, no. 1, (2015), pp. 45-69.

Authors

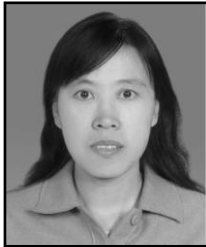

Xiumin Wang, Female, born on April 1, 1963, Professor Master Instructor Associate Dean of information engineering college in China Jiliang University. She hosted a project of National Natural Science Foundation of China in 2013, a science and technology project of the State General Administration of Quality Supervision in 2009, hosted a project of major science and technology project of Zhejiang Province in 2010. She also presided over the completion of four projects of Education Department of Liaoning Province Science Foundation, and presided over the completion of two Hangzhou Science and Technology Program Soft key research projects.

