

## A SMART Building Automation System

Rohit Chasta<sup>1</sup>, Rajesh Singh<sup>2</sup>, Anita Gehlot<sup>3</sup>, Raj Gaurav Mishra<sup>4</sup>, Sushabhan Choudhury<sup>5</sup>

<sup>1, 2, 3, 4, 5</sup> *University of Petroleum and Energy Studies, Dehradun, India*  
<sup>2</sup>*rsingh@ddn.upes.ac.in*

### **Abstract**

*The building energy management systems its control and automation in buildings has significant role. These systems can play an important role in regular energy monitoring and management and therefore to save the possible energy and cost. The key point of the building automation market is focused upon better facilitation to the user in terms of comfort at reduced operation cost. Energy efficiency improvement will also contribute to environmental protection. Therefore there have been regulations and rating systems made that mandates the requirement of energy monitoring and control in a building. For example, the above mentioned building utilities and equipment control and automation plays an integral role in achieving the green building rating points from certifying authorities such as GRIHA and IGBC. The proposed system is to control the active systems such as lighting including artificial lighting (on/off & dimming control), air conditioners and safety features like fire alarm & gas alarm. In future the existing idea can be implemented for the whole building, i.e. various rooms or areas and then all of them can be integrated on a common platform for monitoring and control of different equipment.*

**Keywords:** *Energy Efficient, Automation, RF modem*

### **1. Introduction**

Mostly the building HVAC systems run on set schedules and without fine grained control on in basic information. The design and implementation of sensor nodes are needed for accurate usage of energy on the basis of individual detection [1]. The building energy management systems are important to use energy efficiently. The need for the thermal and visual comfort is increased day by day. The systems are designed for continuous energy management for the accomplishment of the energy and cost savings [2]. The building is a critical area for measuring the impact of energy usage. The wireless sensor network is proposed to monitor and control physical parameters as well as monitoring the presence of users in the rooms [3]. Building automation system presents automatic control of the conditions of interior environment. The main goal is to recognize significant savings in energy with low cost. The BAS has extended to implement information from multiple systems working on “intelligent buildings” [4]. To attain a major reduction in energy utilization apart from the typical energy-efficiency methods, innovative technologies must be employed. Therefore logicity of customary and new energy efficiency options becomes necessities. To move towards the thought of sustainable buildings, a small amount of advanced steps are required, regarding energy, water, land and material management, collectively with environmental loading, and the characteristics of the indoor and outdoor environments [5]. A building energy simulation is discussed which is based on sub hourly occupancy based control. It enables the behavioral models in superior lighting simulation programs [6]. Present monitoring control modules compute load current and power monitor modules examine power

consumed by selected loads, both modules transmitting bus messages signifying load status and status changes. The utility company can access chosen utilization data and control at least a few loads via message exchange to and from microcomputers [7]. User activity and behavior including occupant presence is taken as a main element and has been used for control of a variety of devices like intelligent lighting and HVAC. The most capable and suitable activity detection technologies and approaches allow in developing principles and perspectives for user friendly energy efficient buildings [8]. Wireless sensors and their networks have approached ahead in the field of recently developed technologies. The application of these sensors and the prospects of managing them into networks have discovered many research matters and have emphasized new ways to deal with definite problems [9]. To develop indoor building climate at cheaper costs building automation systems are employed. By implementing wireless sensor network based on BAS, the requirement for cabling is reduced and it lowers the installation and operational expenses also [10].

## 2. Proposed System

A hybrid system is proposed where various sensors are connected with the Arduino board. Gas and fire sensors are connected for the emergency alert. LDR (Light Dependent Resistor) sensor is connected for sensing the light intensity level in the concerned area or room, PIR (Passive Infrared) sensor for sensing the occupancy in the room, a magnetic reed switch door is also used for better and accurate detection of occupancy. LM35 sensor for measuring the room temperature is also used. System is designed to control the lightning system based on the LDR and PIR sensor for on/off and dimming of light and air conditioner control as per requirement, autonomously. Also the system is designed to alert for gas leakage and fire with a hooter.

Fig.1 shows the block diagram for sensing unit in which the main control unit is the Arduino Uno board. Basically six building block of the system are Data Acquisition Unit (Sensors), Controller Unit, Display Unit, RF Modem, Power Supply Unit. In the transmitter section the various sensors are connected to the controller unit. Analog sensors are connected to the analog inputs of the controller and digital sensors are connected to other pins of controller because they provide either HIGH or LOW output. The data from various sensors is fed to controller unit and the data of the sensors unit and at the same time this data is serially provided to RF Modem which wirelessly transmits this data.

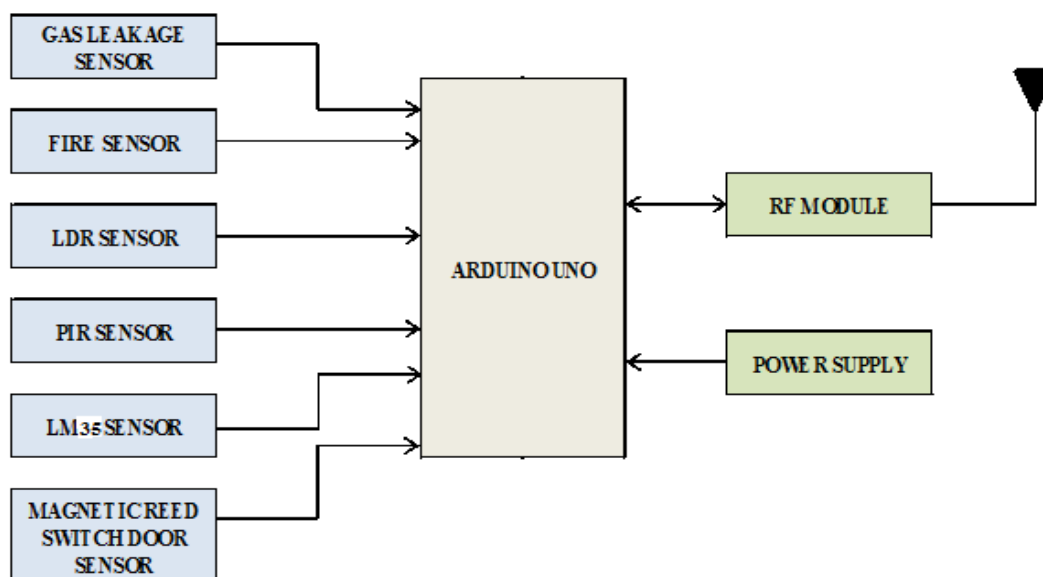
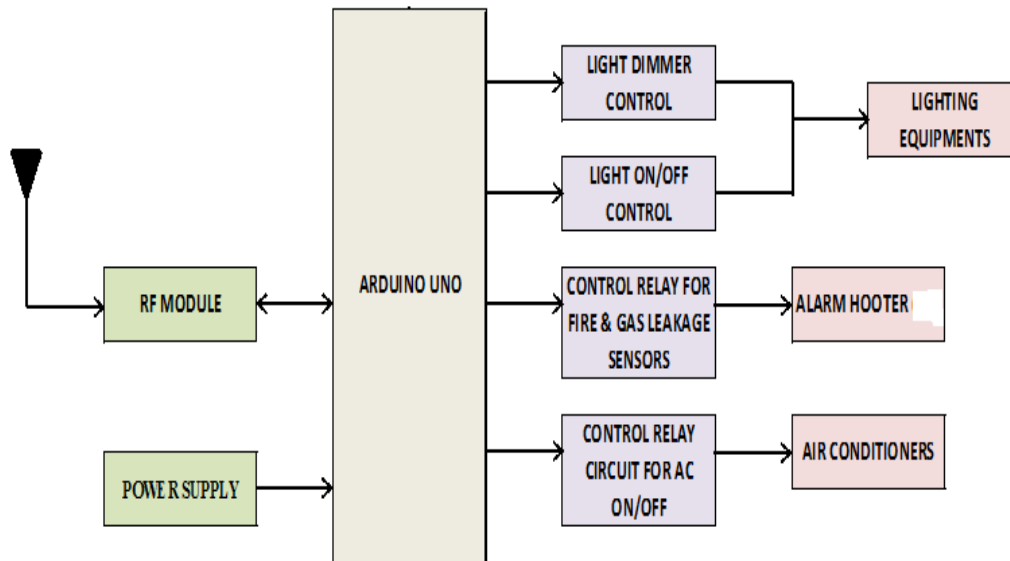

Figure 1. Block Diagram for Sensing Unit

Fig.2 shows the block diagram for receiving unit. In the receiver section basic building blocks of the system are Arduino Uno board, RF Modem and control circuits. This section receives the data transmitted by the transmitter section and this data is processed by the controller unit and according to the sensor data parameters further various control circuits are activated.

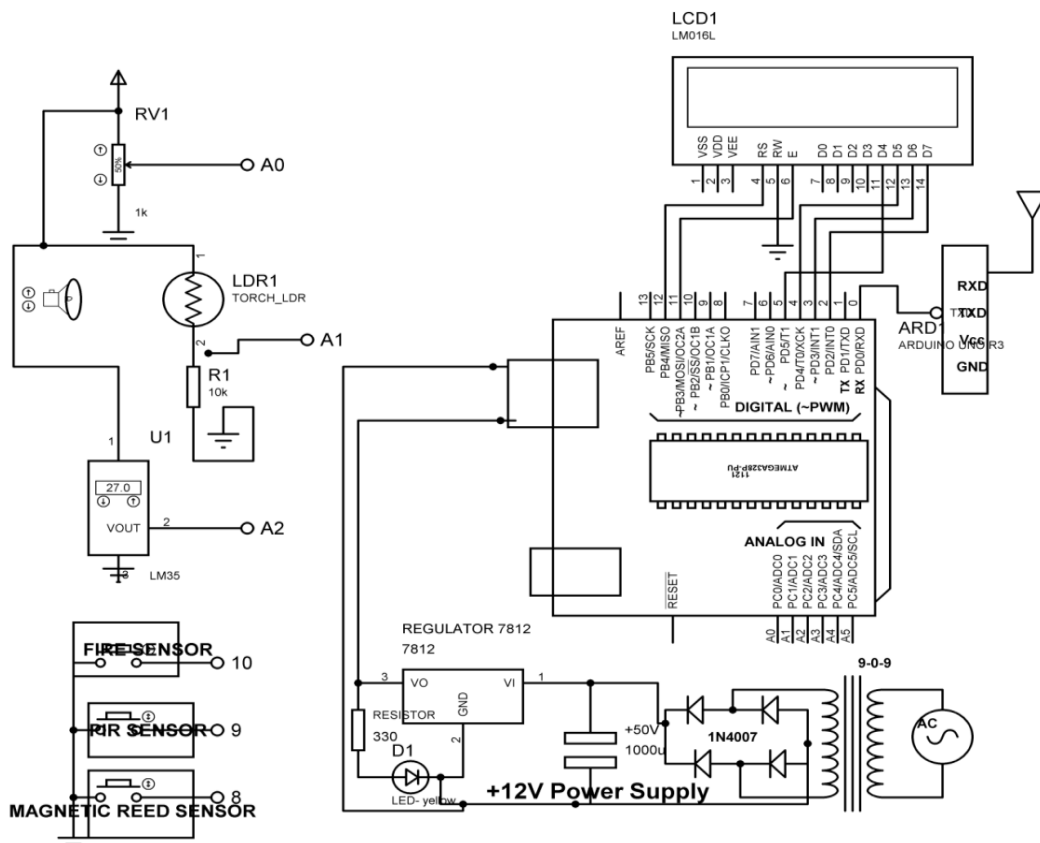

**Figure 2. Block Diagram for Receiving Unit**

After the signal received by RF module, on the output side different outputs are given. Lightning system is controlled through the dimmer circuit as per the inputs from LDR sensor connected at the transmitter section. Air conditioner is controller with relay circuit to on/off the device. Hooter is controlled with relay circuit corresponding to inputs from gas sensor and fire sensor. The above explained methodology is proposed to be implemented for a room in a building for better analysis in terms of energy and cost savings.

### 3. Circuit Diagram

Arduino Uno board is used as the controller unit of the system through which data is detected with the sensors and transmitted to the receiver section and according to which various control operation are performed.



**Figure 3. Circuit Diagram for Sensing Unit**

Fig.3 shows the circuit diagram for sensing unit in which the analog sensors are connected to A0-A5 pin of the controller unit. The controller unit has 10 bit ADC which convert the analog input in to 1024 level as  $2^{10}=1024$ . The fire sensor, PIR sensor and magnetic Red sensors are connected to the pin no. 8, 9, 10 of the controller unit.

Power Supply unit consist of four diode 1N4007 followed by the filter capacitor. For the regulated output IC7805 is used which provides 5V output and the output is provided to various sensors and RF modem. The RF modem is connected at Tx pin of the controller.

Figure 4 shows the circuit diagram of the receiving unit. RF modem receives the data and put this data to the Rx pin of the controller unit. To operate the various AC devices the relay circuits are used.

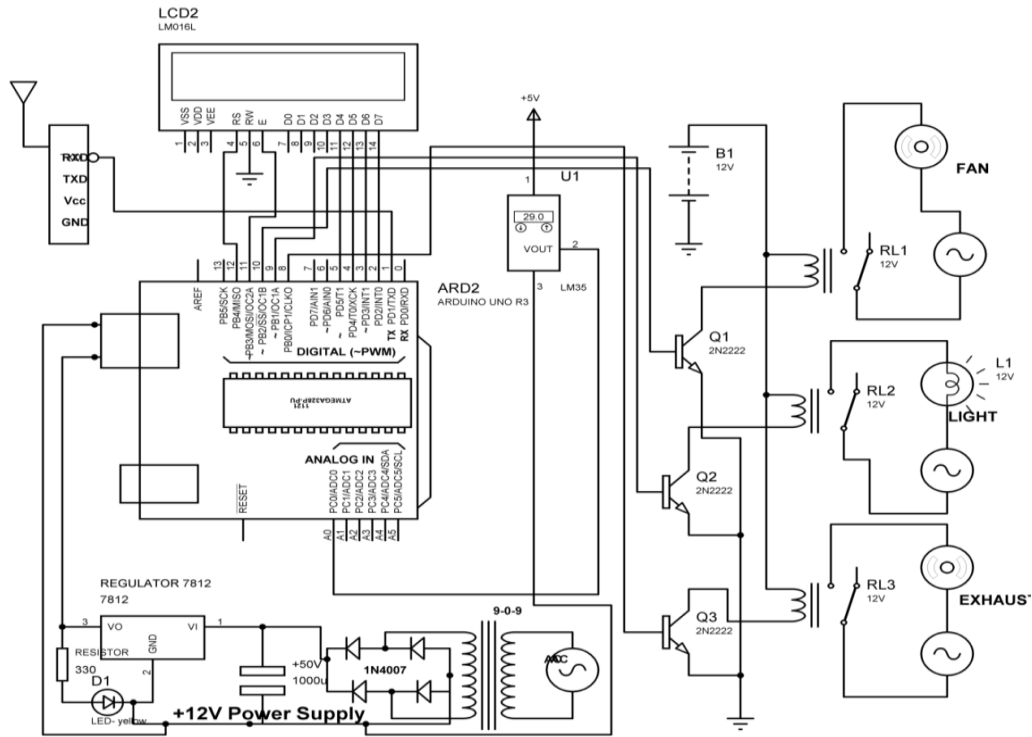

Figure 4. Circuit Diagram for Receiving Unit

#### 4. Results and Conclusion

The proposed system is tested on the Simulation software Proteus. The system model is developed with the circuit diagram. Proteus Simulation is virtual platform where components are connected in the workspace and run for simulation results.

Fig.5 and Fig.6 shows the Proteus simulation models for transmitter and receiver of the proposed system. In this the various digital sensors are denoted with the push button through which the status is read and operated accordingly.

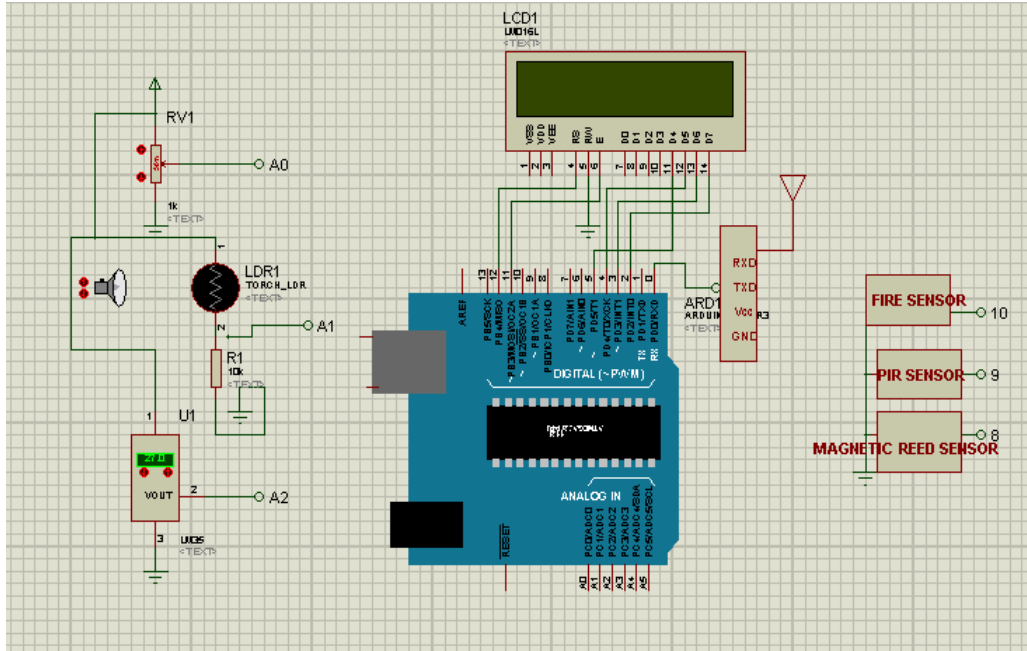

Figure 5. Proteus Simulation for Sensing Unit

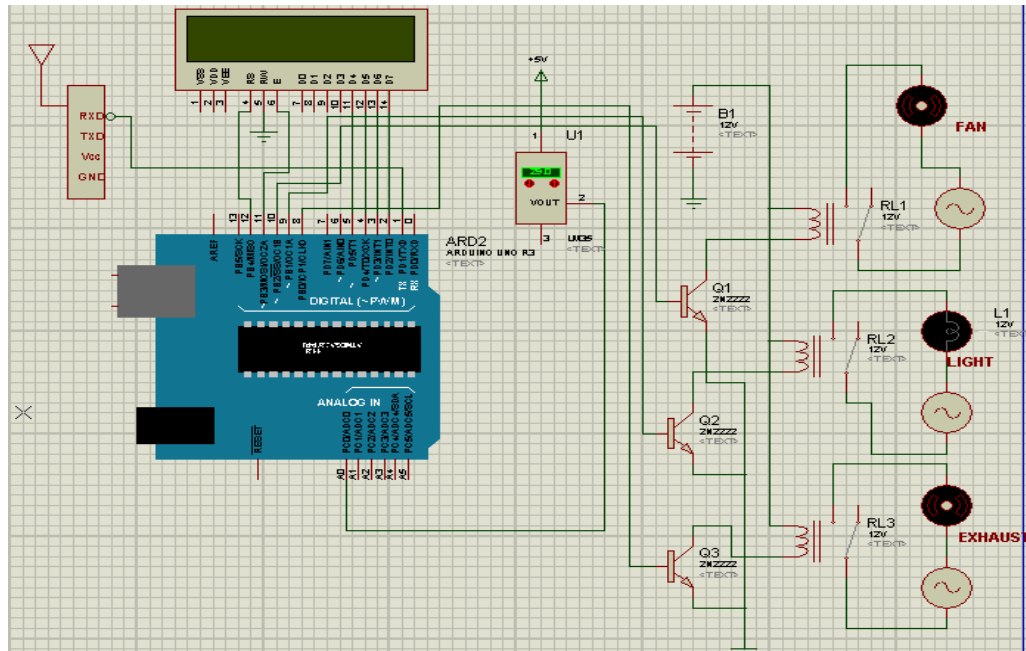
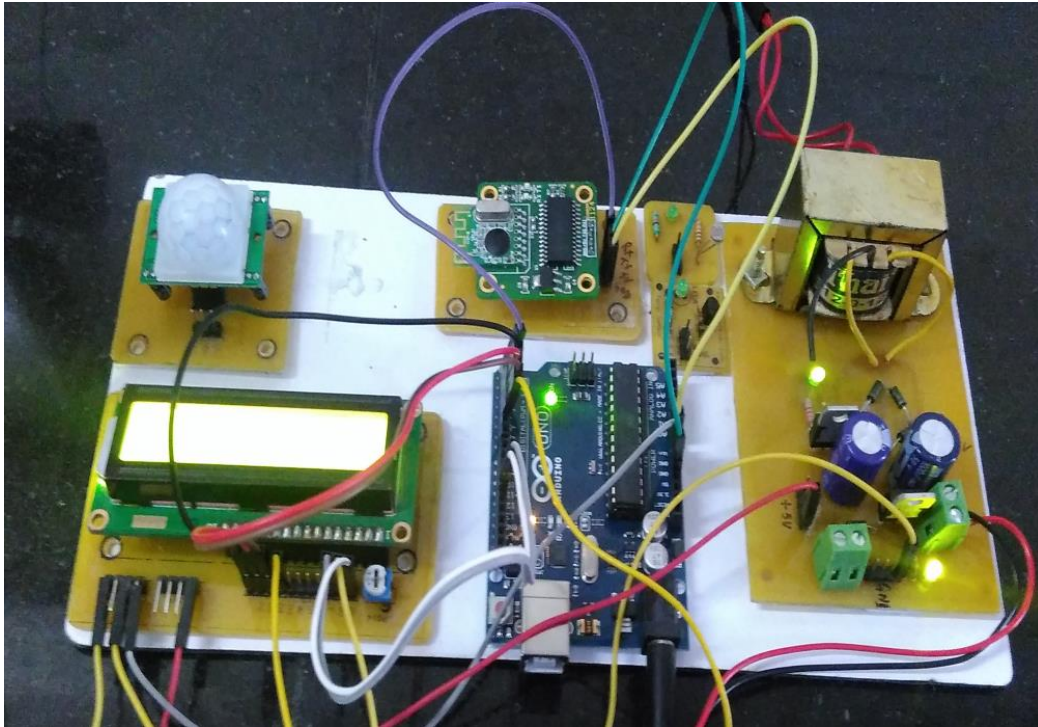

Figure 6. Proteus Simulation for Receiving Unit

The results can be concluded with the fact that the result shows the building energy management system which is capable of controlling the room environment with some safety features. Although, most of the functions and applications are still to implement and only a small amount of accomplished services and products have developed into as available applications for public use, then also there is outstanding attempt and advancement are seen in market. Wireless sensor networks are nowadays measured as mainly the most capable and flexible technologies for constructing inexpensive and easy-to-deploy sensor networks in situations similar to those measured by energy intelligent

buildings. The result shows the designed system is capable of handling multiple devices efficiently and reduces the energy wastage due to human laziness. Some of the basic safety features are also added. Simulation and developed system result shows the proper working of the system. Fig.7 and 8 shows the snapshots for the developed prototype to realize the proposed system.



**Figure 7. Snapshot1 for Developed Prototype**

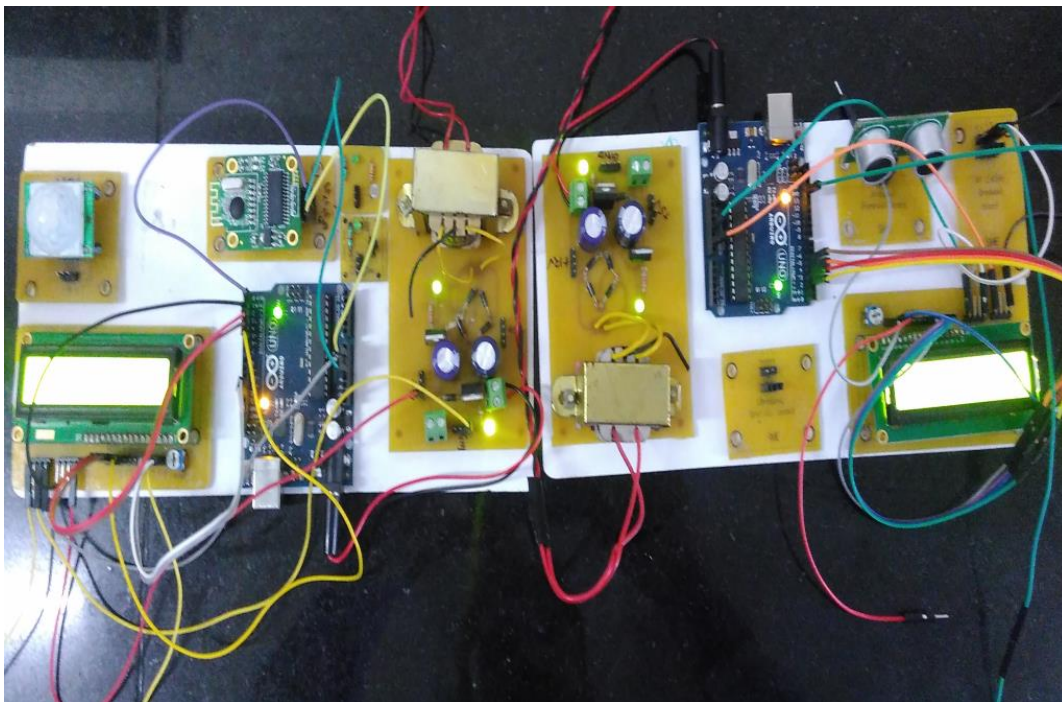

**Figure 8. Snapshot2 for Developed Prototype**

## References

- [1] Agarwal, Yuvraj, et al. "Occupancy-driven energy management for smart building automation." *Proceedings of the 2nd ACM Workshop on Embedded Sensing Systems for Energy-Efficiency in Building*. ACM, 2010.
- [2] Doukas, H., Patlitzianas, K. D., Iatropoulos, K., & Psarras, J. (2007). Intelligent building energy management system using rule sets. *Building and Environment*, 42(10), 3562-3569.
- [3] Barbato, Antimo, et al. "Home energy saving through a user profiling system based on wireless sensors." *Proceedings of the first ACM workshop on embedded sensing systems for energy-efficiency in buildings*. ACM, 2009.
- [4] Kastner, W., Neugschwandtner, G., Soucek, S., & Newman, H. M. (2005). Communication systems for building automation and control. *Proceedings of the IEEE*, 93(6), 1178-1203.
- [5] Chwieduk, Dorota. "Towards sustainable-energy buildings." *Applied energy* 76.1 (2003): 211-217.
- [6] Bourgeois, Denis, Christoph Reinhart, and Iain Macdonald. "Adding advanced behavioural models in whole building energy simulation: a study on the total energy impact of manual and automated lighting control." *Energy and Buildings* 38.7 (2006): 814-823.
- [7] Ehlers, Gregory A., Robert D. Howerton, and Gary E. Speegle. "Energy management and building automation system." U.S. Patent No. 5,572,438. 5 Nov. 1996.
- [8] Nguyen, Tuan Anh, and Marco Aiello. "Energy intelligent buildings based on user activity: A survey." *Energy and buildings* 56 (2013): 244-257.
- [9] Arampatzis, Th, John Lygeros, and S. Manesis. "A survey of applications of wireless sensors and wireless sensor networks." *Intelligent Control, 2005. Proceedings of the 2005 IEEE International Symposium on, Mediterrean Conference on Control and Automation*. IEEE, 2005.
- [10] Österlind, Fredrik, et al. "Integrating building automation systems and wireless sensor networks." *Emerging Technologies and Factory Automation, 2007. ETFA. IEEE Conference on*. IEEE, 2007.