

Modern Control Techniques in Wind Turbine

Ali Oudah¹, Izzeldin I. Mohd² and A. Hameed³

^{1,3}*Faculty of Manufacturing Engineering*

²*Faculty of Electrical & Electronics Engineering*

Pekan, 26600,

Universiti Malaysia Pahang

¹*Mark6ge@ge.com*, ²*izzeldin@ump.edu.my*, ³*a.hameed@gmail.com*

Abstract

As wind energy becomes a larger portion of the world's energy portfolio and wind turbines become larger and more expensive, wind turbine control systems play an ever more prominent role in the design and deployment of wind turbines. The goals of traditional wind turbine control systems are maximizing energy production while protecting the wind turbine components. As more wind generation is installed there is an increasing interest in wind turbines actively controlling their power output in order to meet power set-points and to participate in frequency regulation for the utility grid. This capability will be beneficial for grid operators, as it seems possible that wind turbines can be more effective at providing some of these services than traditional power plants. Furthermore, establishing an ancillary market for such regulation can be beneficial for wind plant owner/operators and manufacturers that provide such services. In this tutorial paper we provide an overview of basic wind turbine control systems and highlight recent industry trends and research in wind turbine control systems for grid integration and frequency stability.

Keywords: *Modern techniques, wind turbine, controllers*

1. Introduction

The wind industry has experienced large growth rates over the past decade and wind turbines have been installed around the world in increasing quantities [1]. As wind energy becomes more prevalent there is growing interest in controlling wind turbines or wind plants (a cluster of wind turbines as seen in Figure 1) in an intelligent manner to minimize the cost of wind energy. This can be done by controlling the turbines to extract more energy from the wind and reduce structural loads that can cause component failure and is the focus of ongoing research. Though wind energy makes up a relatively small amount of global energy production, there are certain regions that produce a significant portion of their energy from the wind, such as Spain, Ireland, and Denmark [1]. The increasing penetrations of wind energy in these countries has raised interest in a new branch of wind turbine control research and development that focuses on wind turbine participation in frequency regulation for the utility grid.



Figure 1. A Row of Turbines in a Wind Plant Located in Alberta, CA. This Wind Plant Contains 114 Horizontal Axis Wind Turbines (HAWTs), each Rated at 660 kW with a Rotor Diameter of 47m and Hub Height Approx 50m

Grid operators require conventional utilities to provide regulation in order to maintain the necessary balance between generation and load, which in turn regulates the grid frequency. Wind power has not historically been required to provide grid regulation services, as most modern wind turbines do not intrinsically provide any of the grid regulation services that are available with conventional generators. High wind penetration levels in the aforementioned countries have led their transmission system operators to impose new requirements for future wind plant installations to be capable of providing power tracking and frequency regulation services [2] when there is ample wind resource available. The interest in the potential for wind turbines to provide regulation services has motivated new opportunities in control system research and development. Wind turbines do not inherently provide these services, but they can be synthesized through designed control actions. Services that involve varying the active power output of the turbine will be referred to as active power control (APC). The new requirements by aforementioned European grid operators have forced turbine manufacturers to develop and implement control methodologies to provide APC capabilities. Ongoing research is focused on determining the upper bound of frequency regulation capability of wind turbines, as it seems possible that wind turbines could be more effective at providing some of these services than traditional power plants. The possible benefits of continuing the development of these methods present good opportunities for both grid operators and wind plant owner/operators. The intention of this paper is to introduce the controls engineer to standard wind turbine control systems and provide a brief overview of the methodologies used to provide APC with wind turbines. This paper is organized as follows: Section II highlights the recent growth in the wind energy industry and provides a general overview of the wind turbine structure, standard control configurations, and an introduction to the interaction of wind turbines within a wind plant. Section III explains the basics of frequency regulation, provides the motivation for developing active power control in wind turbines, and overviews methodologies implemented by manufacturers thus far to meet these requirements. Section IV reviews the prior and ongoing research of enabling APC on wind turbines and wind plants. Finally, Section V provides concluding comments.

2. The Basics of Harnessing Wind Energy

In this section, we highlight the recent growth in the wind energy industry and provide an overview of the most common utility scale wind turbines, their operating regions, their standard control goals, and the interactions between turbines when grouped in a wind plant.

A. Growth of the Wind Energy Industry

Wind energy is a quickly growing alternative energy technology that can provide clean power. According to the World Wind Energy Association, the average growth rate of installed capacity around the world over the last decade has been 27.7% [1]. In 2010, worldwide capacity reached 196,630 *MW* (megawatts) out of which 37,642 *MW* were added during 2010, for a growth rate of 23.6% [1]. During 2010, the United States increased installed wind capacity from 35,159 *MW* to 40,180 *MW*. China almost doubled installed capacity in 2010, growing from 25,810 *MW* to 44,733 *MW*, to pass Germany and the *US* and become the number one country in installed capacity [1]. 2010 brought a 59% capacity increase in offshore wind, bringing the total to 3,117 *MW*, all of which is located in Europe, Japan, and China [1]. As wind turbine technology continues to mature, wind energy is becoming a larger portion of the global energy profile.

The ‘penetration’ of wind energy in the local utility grid, which refers to the percentage of electrical energy generation that comes from wind energy sources, is an important metric to measure. Though wind energy provided only 2.5% of the global electrical energy supply in 2010, several countries have a relatively high percentage of their electrical energy produced by wind power. The countries with the highest percentage of electrical energy generated from wind in 2010 were Denmark, Portugal, Spain, and Germany with 21%, 18%, 16%, and 9%, respectively [1]. It should be noted that these percentages are annual averages. At times the instantaneous percentage of total power provided by wind can be much higher. Wind energy achieved a maximum instantaneous penetration level of 59.6% in Spain in 2011 [3]. The high wind penetrations in these countries have been achieved not only from having good wind resources available, but also by aggressive national policies to produce more energy from renewable sources.

Wind turbines have increased in size to take advantage of economies of scale. The turbines installed in the US during 2010 had an average rated power of 1.79 *MW* with average hub heights and rotor diameters of 79.8 and 84.3 meters, respectively [4]. The average rated power of turbines installed in the *US* has not increased significantly during the past 3 years due to the challenges associated with transporting extremely large turbines over land and the popularity of a particular 1.5 *MW* turbine model [4]. The installation of turbines is also subject to economies of scale, as it is more profitable to cluster wind turbines together to reduce the cost of installation, maintenance, and transmission line construction. These clusters of wind turbines are often laid out in a grid-like pattern and are commonly referred to as wind farms” or wind plants,” the latter being the preferred term which is used in this paper. Figure 1 shows a single row of turbines in a wind plant.

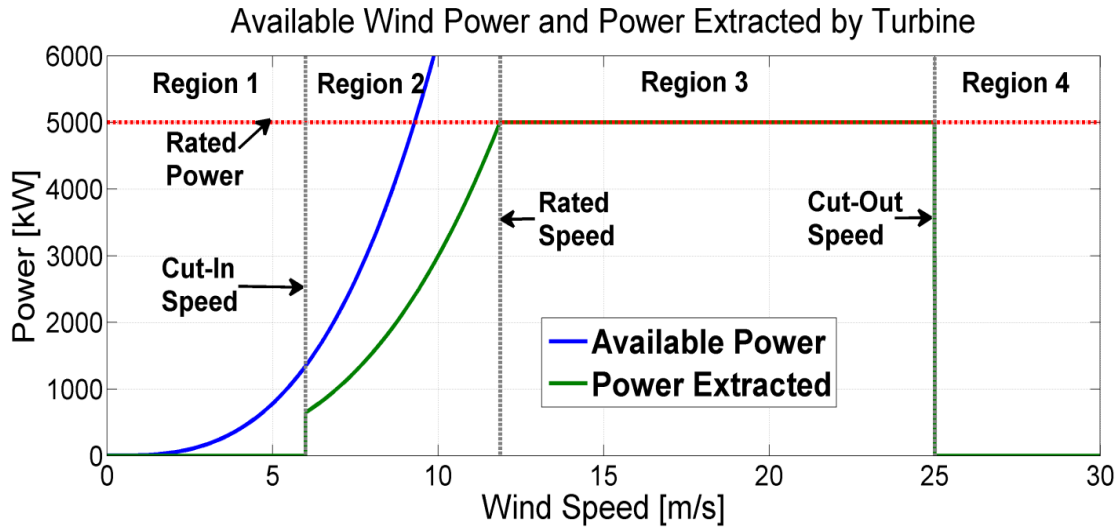

Figure 2. C_p Curves for an Example 5 MW Wind Turbine. The Dotted Lines Represent the Collective Blade Pitch β_* and the Tip-Speed Ratio λ_* at which C_p is a Maximum

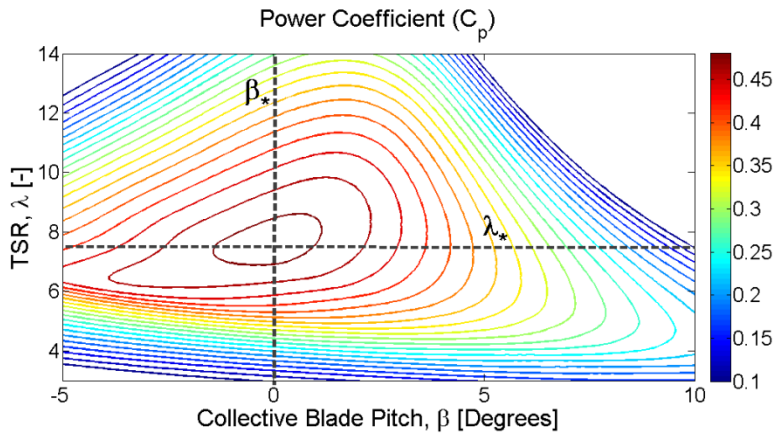

Figure 3. Wind Power, Turbine Power, and Operating Regions for an Example 5 MW Turbine

B. Wind Turbine Overview

A turbine with rotor axis of rotation that is horizontal to the ground is called a HAWT (Horizontal Axis Wind Turbine). HAWTs are representative of the majority of all large scale wind turbines today. These turbines are operated in an upwind manner, where the rotor plane is actively positioned to be directly upwind of the tower through the use of a yaw motor that rotates the entire nacelle (housing for all components located at the top of the tower). Wind passing over the turbine blades produces lift and this then induces a rotational torque.

$$P = \frac{1}{2} \rho A v^3$$

The available power in the wind is P , where P is the power [W] passing through the rotor disk, ρ is the air density [kg/m^3], A is the swept area of the rotor disk perpendicular to the wind direction [m^2], and v is the wind speed [m/s]. The wind turbine rotor cannot extract all of the energy from the wind stream, as this would require the wind to become stationary on the downwind side of the rotor. The fraction of available power that a turbine does harvest is its power coefficient $C_p(\beta, \lambda)$, which is a function of the collective blade pitch β and the tip-speed ratio (TSR) λ . The TSR is the tangential speed of the blade tips divided by the wind speed perpendicular to the rotor plane. ⁴ Characterization of a wind turbines C_p is shown as a contour plot in Figure 2. The theoretical upper limit for C_p is the

Betz Limit of $\frac{16}{27}$ [6].

The aerodynamic torque captured by the blades is transferred to the hub, which connects the blades to a drivetrain and then a generator. Typically, the drivetrain includes a gearbox to scale rotational speed and torque to levels that are suitable for the generator configuration. Although gearboxes are still used in the majority of turbines, direct-drive wind turbines have been developed to directly connect the hub to the generator with a single shaft to increase reliability and reduce maintenance costs that are largely associated with gearbox failures [6].

The wind turbine's generator converts the mechanical power of the drivetrain to electrical power which is either directly injected to the grid or first converted to the grid frequency via power electronics. Most large scale wind turbines installed during the 1980's and 1990's used gearboxes and fixed speed generators that produced voltage synchronous with the utility grid [6]. The wind turbine industry has since moved to using variable speed wind turbines that can maximize below-rated power production by matching blade tip-speeds against prevailing wind speeds to maximize aerodynamic efficiency, as described in Section II Variable speed operation is typically achieved by using one of two different configurations. The first employs a synchronous generator that spins at variable speeds and uses a full power converter to ensure the produced power matches in frequency and phase to that of the utility grid and is known as a 'type 4' wind generator [7]. The second, and most common way of achieving variable speed operation is to use a doubly-fed induction generator (DFIG), known as a type 3' wind generator [7]. The stator of a DFIG is directly connected to the grid while the electromagnets of the rotor are excited by a time-varying waveform that is produced by power electronics that need to only convert roughly 30% of the turbine's rated power [7]. Almost all commercially available large scale wind turbines use either type 3 or 4 generators, both of which effectively decoupled from the grid via their power electronics.

C. Standard Control Configurations

The control of wind turbines is a complex problem and spans multiple fields of research, including materials, aerodynamics, and power systems. As the turbine structures become larger, their components become more expensive. Wind turbine manufacturers may attempt to counteract the increase in costs by using lighter weight components that can be more flexible. These large, expensive, and flexible components can be more susceptible to failure from

fatigue and extreme loads that arise from the turbulent nature of the wind. Control system optimization to prevent extreme loads and to reduce fatigue load cycles becomes important to avoid component failure.

Wind turbine control is typically divided into four primary regions, as seen in Figure 3. Region 1 spans operation from startup to the ‘cut-in’ wind speed where the generator is turned on and starts producing power. When wind speeds are above cut-in, but still too low to produce maximum power, the turbine is said to be in Region 2. In this below rated region the objective is to maximize aerodynamic efficiency to capture as much energy as possible from the wind stream. In Region 3, wind speeds are high enough to drive the generator at its rated power output; in this case, the goal is to regulate speed and power safely at rated levels. Region 4 occurs when the turbine shuts down due to high wind speeds to prevent damage to the turbine.

Throughout these regions, the speed and power of the turbine are controlled by varying the generator load torque and the blade pitch angles based on measurement of the generator shaft speed. The generator torque is induced by power electronics onto the load side of the drivetrain, and actuation is sufficiently fast that it is considered as occurring with negligible delay in comparison with the dynamics of the rotor and structural loads. The blades are actuated with pitch motors which are often modeled as low-pass filters with a cutoff frequency on the order of 1 Hz, saturation limits, and slew-rate limits on the order of $10^\circ/\text{sec}$ [8]. The generator shaft speed is typically measured using an encoder, and the signal is often fed through a low-pass filter to avoid high frequency actuation. Yaw control is also employed during turbine operation to keep the rotor perpendicular to the primary wind direction, typically based on 10-second-average wind direction measurements, with a yaw rate on the order of $0.5^\circ/\text{sec}$ [9].

1) *Region 2 (Below-Rated)*: In Region 2, the primary goal is to capture as much power as possible. The power coefficient C_p changes with both blade pitch and TSR , as shown in Figure 2, and is largely determined by the geometry of each specific blade design. In standard Region 2 control, blade pitch is typically held constant at the value β_* that produces the peak C_p . The goal is then to maintain the TSR at the optimal level λ_* ; hence, the tip-speed, and therefore rotor speed, must vary proportionally to the wind speed. This is achieved by varying the generator torque.

The commanded generator torque τ_g is set according to

$$\tau_g = \frac{1}{N_{gear}} k_\tau \Omega_r^2$$

$$k_\tau = \frac{1}{2} \rho A R^3 \frac{C_p(\beta_*, \lambda_*)}{\lambda_*^3}$$

where N_{gear} is the high-speed to low-speed gearbox ratio (*i.e.*, a constant greater than 1), Ω_r is the rotor speed (measured generator speed divided by N_{gear}), ρ is air density, A is rotor swept area, R is the rotor radius, and (β_*, λ_*) are the blade pitch and TSR , respectively where the maximum power coefficient C_p occurs. It can be shown that this generator torque control law will balance the aerodynamic

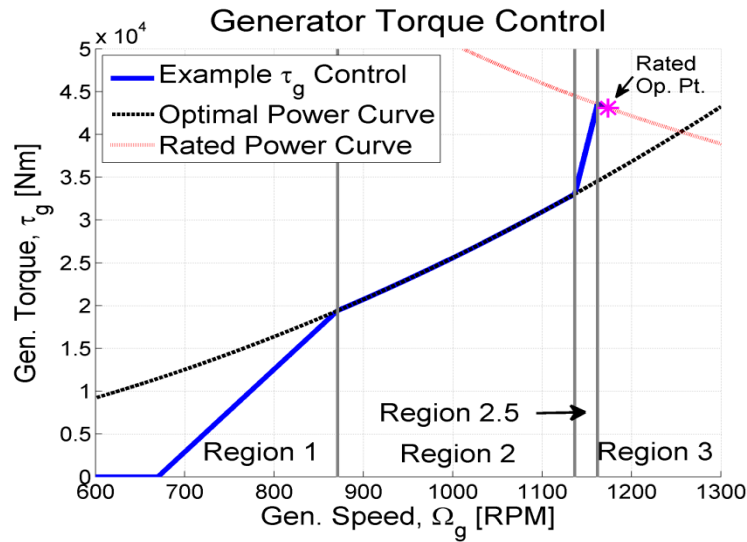

Figure 4. An Example of the Generator Torque Control in Different Operating Regions, as Described in [8]

and load torques to regulate the speed of the turbine to the optimal TSR in steady-state conditions [10]. Figure 4 shows an example of generator torque command versus generator speed measurement, following this law in Region 2, and also showing transition Regions 1.5 and 2.5, as found in [8].

The torque controller may deviate from the optimal TSR at particular speeds to avoid tower resonances, and may also include drive train *and/or* tower damping by adding feedback at the appropriate resonant frequency or frequencies [11]. Though these features and the generator shaft speed measurement filter will not allow the turbine to perfectly track the optimal tip-speed ratio, the peak of the C_p curve is relatively flat and the power capture performance is acceptable.

2) *Region 3 (Above-Rated)*: In Region 3, the primary goal is to regulate generator speed at rated by shedding extra aerodynamic power. This is done using blade pitch control, typically pitching to feather which decreases the aerodynamic angle of attack. The blade pitch angle capturing the most power is β_* , which occurs at 0° in Figure 2. The standard convention is that pitching to feather corresponds to increasing, or positive pitch angles. Pitching to stall (increasing angle of attack) can decrease the rotor speed more rapidly, but pitching to feather decreases aerodynamic torque smoothly, is quieter, and typically induces smaller blade structural loads [5].

The blade pitch control system typically uses proportional- integral (PI) control on the generator speed error signal to regulate the generator speed at rated. The control system also includes anti-wind up or saturation limits on the integrator to account for the physical limits placed on the pitch angle of the blade (*e.g., not allowing the blade pitch to go below β_**). Gain scheduling is often used to adjust the PI gains based on the current blade pitch angle. This is done to address the non

linear sensitivity of the C_p curve to blade pitch angle [8]. This PI speed controller pitches all blades to feather collectively. Individual pitch variations and higher frequency collective pitch variations may also be added to the PI pitch commands in order to reduce structural loads [11].

Because the blade pitch regulates generator speed at rated in Region 3, the generator torque can be held constant at rated torque. However, due to the stochastic turbulent nature of the wind and the slow response of the pitch actuators, at times the generator speed may vary more than 5% from the rated speed. It is common to maintain constant power output in above rated winds by commanding variations from the rated torque that are inversely proportional to fluctuations in rotor speed, as shown in Figure 4.

D. Wind Plants and Turbine Wake Interactions

One area of research still very nascent is wind plant control to address turbine wake interactions. Wind turbines are often installed in wind plants to reduce the cost of installing transmission lines and operations and maintenance costs. As a byproduct of the extraction of energy from the wind, turbines create wakes that extend downstream [12, 13]. Wakes are characterized by lower speed and higher turbulence than that of the surrounding wind. With enough downstream distance, the wake mixes with the surrounding winds so that the wind speed and turbulence become approximately the same as that of the free stream. Turbines operating on the interior of a wind plant are often subject to wakes of upstream turbines as shown by Jensen *et al.*, [14]. Wakes are significant because a turbine operating in the wake of an upstream turbine has less available energy to extract from the wind and is subject to increased mechanical loads-inducing turbulence. Wake effects translate to less revenue due to decreased power generation and increased maintenance costs.

Wake effects pose a significant challenge for advanced wind plant-level control systems. One method that has been studied [15-17] involves operating the upwind rows of turbines in a plant at a decreased efficiency to reduce wake effects imposed upon downstream turbines, increasing overall plant power capture and reducing loads. Such a scheme could be tuned to the current atmospheric stability conditions at a particular site, since wakes persist more strongly in a more stable (nighttime) atmosphere. Wind farm control and wake interactions are the subject of numerous papers, though not explicitly mentioned here, this research can aid in determining how wind plant level controls can further enable active power control.

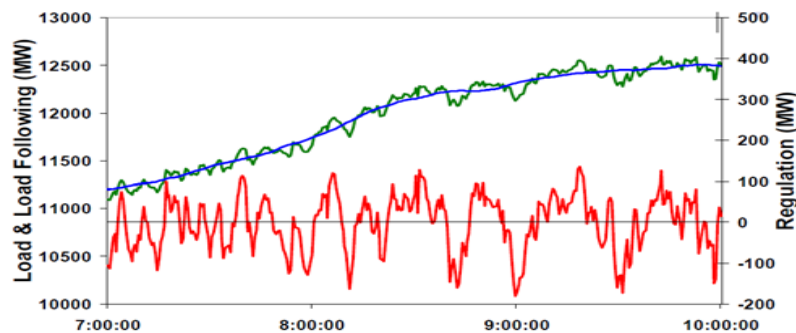

Figure 4. An Example of the Generator Torque Control in Different Operating Regions, as Described in [8] and Load Torques to Regulate the Speed of the Turbine to the Optimal in Steady-State Conditions [10]

3. Overview of Apc

In this section, we present a brief overview of how grid frequency control is provided via conventional sources. We also explain the motivation for wind energy to provide active power control by presenting current frequency support requirements by some transmissions systems operators (TSOs). We then review industry activity to develop solutions that provide active power control capabilities that meet the new requirements.

A. Frequency Regulation Basics

In order for the grid to maintain a desired frequency, it is necessary that the total power generated be equal to power consumed by system loads and electrical losses on the grid. This balance must be preserved in the face of fluctuations in load and uncontrolled generation. If generation exceeds load, then the grid frequency will go up, whereas if total load exceeds generation, grid frequency will fall. Therefore, *regulation* provided by capable utilities is used by grid operators to compensate for these fluctuations and unplanned events such as sudden loss of generation [18]. Such capable utilities include regulation-providing generators or grid-responsive loads and storage. Figure 5 provides an illustration of the utility grid's power generation (blue), load (green), and the regulation required (red) to match supply and demand (from Kirby [18]) line represents load-following generation. The red line represents regulation required to keep generation balanced with load (reprinted with permission from [18]).

Conventionally, grid frequency response to a large disturbance is divided into separate control regimes: inertial, primary frequency response, and secondary frequency response or automatic generation control (*AGC*). These classifications are based on methods for providing each service with conventional generators: synchronous generator inertia for inertial response, generator governors for primary response, and finally output control responding to system operator power level demands for *AGC* response. For further information and exact definitions of inertial, primary, and secondary response, see [19] and [20]. It should be noted that some references refer to inertial control as a subset of primary response. Figure 6 provides a plot of these regimes in the case where there is a sudden loss in total generation connected to the grid, and is depicted in terms of a time-domain plot of grid frequency following the loss of generation. The inertial response immediately follows the frequency event, primary control usually occurs within the timeframe of 20-30 seconds, and secondary control occurs within the timeframe of 5- 10 minutes. The inertial response is conventionally determined by the physical inertia of large synchronous generators as they decelerate in response to the increased electrical load during a loss in total grid generation capacity. The frequency decline is arrested or stabilized in the second time frame, which is characterized as the primary response, or governor response, as it is normally automatically controlled by generator governors responding directly to changes in grid frequency. The final response, in which the frequency is restored to nominal, is called *AGC* and is performed

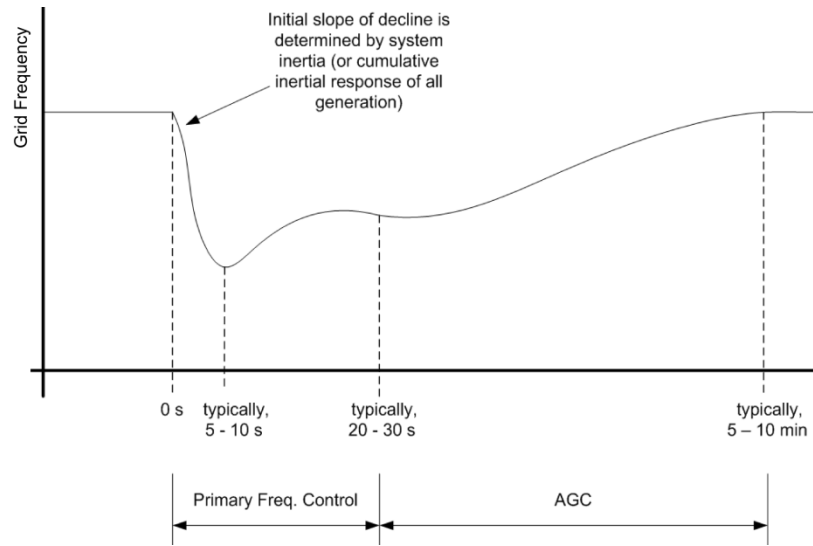

Figure 6. Inertial, Primary Frequency Controls, and *AGC* (Secondary) Response
 (Figure Courtesy Pouyan Pourbeik of EPRI)

by individual power plants adjusting their power levels in response to requests from the systems operator.

B. Motivation for Active Power Control in Wind Turbines

Active power control (APC) is the purposeful control of the real power output of a wind turbine or collection of wind turbines in order to assist in balancing total power generated on the grid with total power consumed. Real (also known as “active”) power is the portion of energy flow which results in a net transfer of energy; this is in contrast to imaginary or reactive power flow, which reverses direction over each cycle with no net energy transfer. While reactive power may be controlled through the turbine’s power electronics (even when the turbine is offline), real power is regulated by changing the actual amount of power delivered to the utility grid. In doing so, APC may allow wind power to provide important ancillary services to the electrical grid and assist in maintaining an acceptable frequency.

Intrinsically, wind turbines do not provide APC services and they have not historically been required to provide such responses [21]. Most modern turbine generators are decoupled from grid frequency through power electronics (type 3 or 4), as described in Section II-B. Therefore, the inertia of the generator and the turbine rotor do not automatically participate in the grid inertial response as would traditional synchronous generators. Further, because of this decoupling, changes in grid frequency do not elicit an automatic governor response that is common with conventional generation sources.

Increasingly, there are two main motivations for why APC should be provided by wind turbines. The first motivation is that regulation is essential for maintaining grid frequency and as wind penetration increases it can provide key support in maintaining the required balance.

A FERC/LBNL (Federal Energy Regulatory Commission/Lawrence Berkeley National Laboratory) study discusses a recent decline in grid frequency response, and states that although increasing wind penetration is not the cause, frequency response could be improved through the expanded use of frequency control capabilities in wind turbines [22, 23]. Further, a recent study by the IPCC (Intergovernmental Panel on Climate Change) found that although

low to medium wind penetrations (up to 20% of annual demand) poses no “insurmountable technical barriers,” higher levels could require additional flexibility options such as greater use of wind power curtailment and output control [24]. As wind energy penetration increases, it is potentially displacing regulation-providing generators. At very high wind penetration levels it becomes necessary for wind turbines to also provide these services [21] as it has for several European grid operators.

In countries and regions with relatively isolated grids and relatively large levels of wind penetration, participation in grid frequency regulation by wind turbines and wind plants is crucial. A 2010 report issued by Project UpWind [2] indicates that replacing conventional generation sources with a large percentage of wind power not capable of active power control can potentially have significant impacts on stability of grid frequency. This effect is pronounced on island grids with low levels of interconnectivity to other grids, such as many of the Greek isles [25].

The necessity of participation in grid frequency regulation by wind turbines is reflected in the requirements and regulations put on wind plants by TSOs in regions with high levels of wind penetration or relatively isolated grids. For example, the Irish grid code requires that wind plants have active power curtailment capabilities, and outlines specific active power generation set-points as a function of available power in the event of a frequency deviation [26]. This code further specifies a minimum response rate for individual turbines of 1 % of rated power per second. Elsewhere, Denmark’s TSOs Eltra and Elkraft require that wind plants be able to track a reserve power offset and track reference power levels generated by the system operator [27]. In Canada, Hydro-Québec requires that wind plants rated above 10

MW have the ability to modify their active power output for at least 10 seconds in response to grid frequency deviations greater than 0.5 Hz [28]. Additionally, the Spanish **TSO**, Red Eléctrica, mandates that wind plants respond to frequency deviations with proportional control of active power output within a range of percentages of rated power [29].

The second motivation for active power control by wind turbines is the potential to increase the profitability of wind plants by enabling participation in ancillary service markets. A recent study by Kirby demonstrates a potential for wind plants to “increase their own profits by providing regulation” [30].

*C. Industry Activity in Support of **APC***

The various active power control requirements laid out by grid operators have motivated technological development by wind turbine manufacturers. These developments have been made at both individual turbine and wind plant scales. Technologies to provide response in all of the inertial, primary, and secondary time scales have been developed at the individual turbine level. For example, Siemens has patented a method for dynamically modifying an individual turbine’s active power output in response to grid frequency deviations

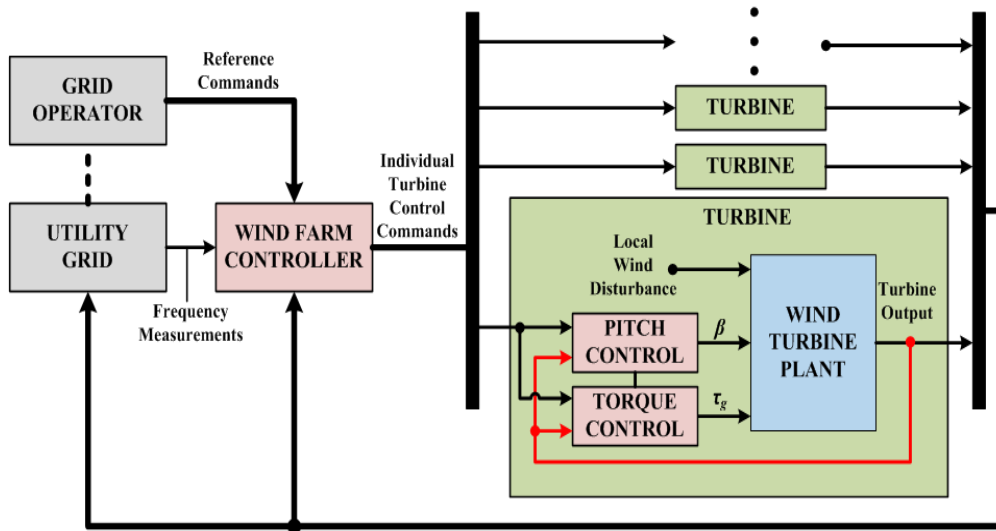

Figure 7. ^A Block Diagram that Shows the General Interconnection for APC Commands

The wind plant controller can measure the frequency of the utility grid and receive a power command signal from the grid operator and in turn produce a power reference for each turbine in the wind plant. On time scales similar to inertial and fast primary responses [31]. Methodologies for monitoring power available in the wind and maintaining a specified amount of active power in reserve are patented by both Mitsubishi [32] and Vestas [33], respectively. In another patent, participation in primary and secondary regulation is achieved by using blade pitch control to specify a percentage of available power as an active power reserve, which can be changed up or down in response to grid frequency fluctuations [34].

Methods for providing active power control of entire wind plants have also been developed. Performing active power control collectively across a wind plant is intended to provide faster response and recovery to grid frequency deviations than can be achieved by performing active power control on individual turbines separately. These plant scale technologies, like those patented by Mitsubishi [35], Ingeteam [36], and General Electric [37], have focused on monitoring and forecasting available power in the wind, so that total active power generation by the wind plant can be controlled. Additionally, these patents claim to develop intelligent strategies for communicating wind, power, and frequency conditions between individual turbines. An example of such a strategy can be seen in [36], where a subset of the turbines on a wind plant are used as observers to estimate power available, and the aggregate active power output of the wind plant is set to a percentage of the estimated available power.

Two Danish offshore wind plants, Horns Rev and Nysted, serve as examples of the current state-of-the-art of the industry. Both facilities are outfitted with active power control systems capable of responding to ^{TSO} power set point commands and automatically responding to fluctuations in grid frequency [2]. They have several available operating modes to provide APC, as described in Section IV.

Patent literature is rich with technologies that are designed to meet performance demands set forth by TSOs and allow for control of active power output. It appears that current

industry standards for maintaining an active power set-point is performed using pitch control on a relatively slow time scale, leaving inertial and primary response to be handled by controlling the generator and power electronics [2]. However, it would appear that much of this development, especially specific controller topologies, is proprietary information.

4. Implementation and Ongoing Research of APC on Wind Turbines

In this section we present an overview of the existing implementation and the ongoing research of APC on wind turbines. These two topics are combined into one section because the current methods of implementation of APC are not made explicitly clear by turbine manufacturers. Figure 7 shows an example of a standard interconnection of a wind plant controller with the *TSO* or grid operator, utility grid, and the individual turbines. The individual turbine can follow the power reference from the wind plant controller by altering the standard generator torque and blade pitch feedback loops, which are described in Section II-C. Increasing the regulation performance of a wind turbine control system can be complicated due to a number of factors, including coupling with existing control loops, a desire to limit actuation usage and structural loading, and wind variability.

As described in Section III, several European TSOs now have requirements for new wind plants to provide inertial response emulation to frequency events and to track either a delta or absolute power reference signal at a required slew rate. The new requirements by the TSOs have led to the development of APC on wind turbines to meet two different goals. The first is ‘automatic frequency control’ which is designed to emulate the inertial response of conventional generators over a limited time window immediately following a frequency event. The second goal of APC controllers is met by tracking a power reference from the TSOs over longer time scales as a secondary, or *AGC* response. The minimum requirements have been met by manufacturers, but ongoing research is being performed to improve the implementation of such controllers and to determine the extent of the regulation capabilities that can be provided

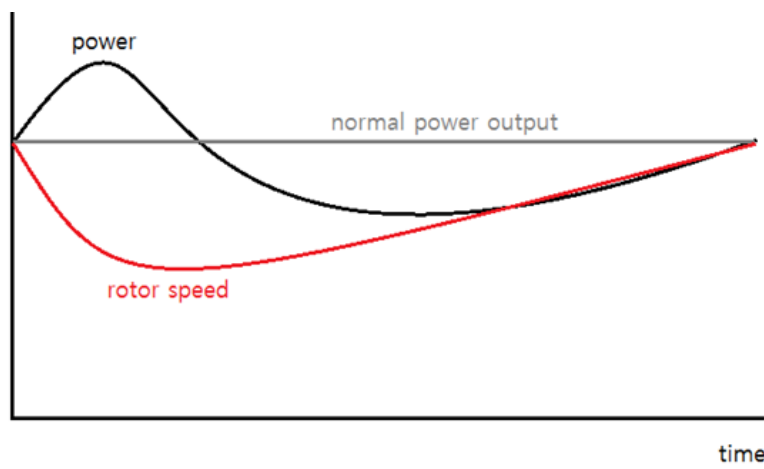

Figure 8. Inertial Response Emulation showing Sudden Electrical Power Increase with a Long Recovery Period

by wind turbines. These areas of on-going research include variations of control methodologies to implement inertial or *AGC* response, advanced controllers that combine

torque and pitch control to implement primary control during frequency events, and analysis of impacts on turbine lifespan induced by implementing active power control strategies.

A. Inertial and Primary Response

Inertial response emulation, which is also referred to as inertial control or kinetic energy control, is now required by several European TSOs (Section III) to help regulate the grid frequency when events occur such as that depicted in Fig. 6. This response is implemented in a wind turbine or wind plant by measuring the frequency of the utility grid and using a control algorithm to vary the output power to compensate for deviations in grid frequency. The inertial control is performed over a short time scale typically by the generator torque control to emulate the built-in response of a conventional generator [2]. Wind turbines have the capability of providing more inertial frequency regulation than conventional generators per unit of spinning inertia, due to the speed at which the power electronics can actuate the torque command signal [7].

Inertial response emulation typically provides fast increases (or decreases) in the power production through sudden increases (or decreases) in the generator torque. It is more common to have a conventional generator fail than for a large load to drop from the grid, so here we look at the case where there is a demand for a sudden increase in turbine power. A rapid increase in generator torque will cause the rotor to decelerate while power is produced above the power set-point, as shown in Figure 8. The downside of this method is a danger of the turbine stalling and possible added loading on the mechanical parts. This response is used to increase power in the short term and often requires a period of recovery as depicted in Figure 8. This recovery period can be problematic in that it can cause the wind turbine to produce less power after the inertial response, which could adversely affect grid frequency. However, research in [38] shows that inertial response emulation can sometimes be more effective than inertial response from conventional generators in coal power plants, covering a wider frequency range.

There are multiple approaches to extract additional power from the spinning rotor mass and still handle recovery. Both [39] and [21] use the previously mentioned method of quickly increasing torque in response to grid frequency falling, which thus causes a deceleration of the rotor speed and is called “Kinetic Energy Control I (KEC I)” and “*GE* WindINERTIA,” respectively. While some variation of KEC I is the most intuitive method for inertial response emulation, [39] goes on to propose another method called “Kinetic Energy Control II (KEC II),” which allows the rotor to accelerate initially before applying the higher torque. The benefit of KEC II is that the turbine power and rotor speed do not fall below normal operation speed throughout the whole course of power extraction, eliminating the recovery period and preventing turbine stall. However, a temporary over-speed can be caused when operating at rated power, and may not be a desirable solution. Another concern with KEC II is that the response speed could be delayed due to the speed-up process, and the magnitude of frequency drop can be more severe than with KEC I.

While conventional synchronous generators automatically provide inertial control and have governors for primary control, the distinction between inertial and primary responses is less clear for wind turbines without these governors. While patents for such technologies apparently exist, the methods by which primary response is achieved are generally not explicitly outlined. Consequently, primary APC of wind turbines is an ongoing area of research.

Another method of extracting additional power from the rotor inertia while enabling a primary response is covered in [40] and [41]. Both of these studies operated the turbine at higher than optimal tip-speed ratios to maintain a reserve of available wind power. With an overhead of un-utilized power, in an under frequency event, the controller can increase the generator torque to extract inertia from the turbine, causing the turbine to slow down to the optimal tip-speed ratio. These controllers therefore implement inertial response and a primary response as they produce a higher power output in response to the detection of under frequency events. This can be seen in Figure 9, where if derated by 10% at 10 m/s wind speed and commanded to ramp up to rated power, the turbine would follow a trajectory from point A to point B. Pitch control is also used in [40] to derate the turbine and add to the primary response, but there is no consideration of stability issues arising from the interaction between the torque and pitch control loops, and simulations were only performed under constant, uniform winds. The fundamental concept in these works is worth noting, but further research in this area is required as neither [40] or [41] address the persistent over-speeding of the turbine while running in above-rated winds or the controller's effect on the structural loads of the turbine. Inertial and primary control can be implemented and simulated at the wind plant level. Patent literature, such as [36], suggests that intelligent, distributed response of an entire wind plant to a frequency disturbance could potentially minimize overall grid frequency deviation and improve

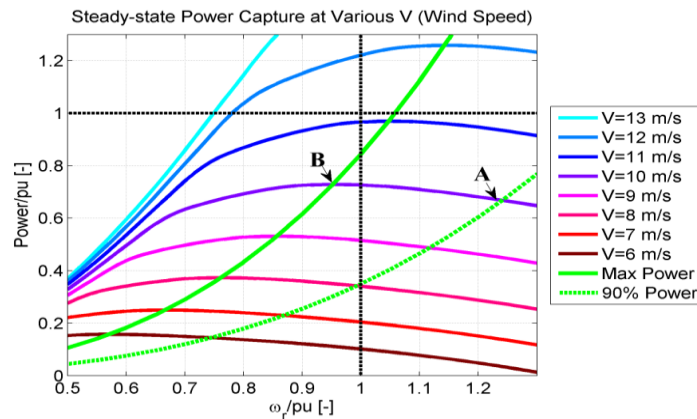

Figure 9. Various Steady-State Power Capture Curves for Given Wind Speeds

The 'Max Power' line is the trajectory of the turbine that achieves maximum power capture for each wind speed and the '90% Power' line is the trajectory that leaves 10% overhead power via rotor speed control. The axes are normalized to the rated values recovery speed. Primary grid response to frequency disturbances with varying levels of penetration by wind plants with active power controllers was simulated in [42], with results suggesting that participation in frequency response by wind plants can greatly increase grid robustness and reduce the maximum frequency deviation from nominal during a disturbance. This simulation consisted of the grid represented as an electrical bus and analyzed the effects of the wind plant APC controller when a conventional generator goes offline. While these simulation results are promising, the simulations themselves are limited by their use of a number of turbines much smaller than a typical wind plant and simplified models of turbines and turbine wake interactions.

B. Secondary (AGC) Response

A secondary (AGC) response consists of power plants raising and lowering power output in response to commands from the TSO. Conventional generators typically receive an absolute power reference from the TSO since the power plant can vary the fuel input to meet the power demand up to the plant's rated output. AGC Capable wind turbines and plants also receive their power command signals from the TSO. These commands may be in terms of a 'balance control' or absolute power command signal (so long as that level of power is available from the wind) or a 'delta control' command which specifies the percentage of the available wind power to be captured. Using delta control ensures that there is a percentage of available wind power that is kept as overhead in case the TSO demands more power. There is also often a 'power gradient limiter' that is specified by the TSO which is a lower limit on the rate of change of wind plant power production to meet the TSO's set point [2].

1) *AGC at the Turbine Level*: The most popular methods for reference power tracking by wind turbines appear to be pitch angle control and rotor speed control. These methods intentionally achieve sub-optimal operation with lower C_p (Figure 2) to track the power set-point provided by the TSO. Both [40] and [41] show that pitch angle and rotor speed controls are effective methods for primary and secondary controls of wind turbines. In addition, a similar control scheme called "GE WindCONTROL" [21] shows that the total plant level power output can be controlled to provide a desired response.

A recent study developed several novel combined torque- pitch controllers to respond as quickly as possible to a change in power reference command [43]. Though this study assumes an absolute power reference AGC signal is provided to the turbine control system, a primary response can be achieved from this controller if the power reference signal is augmented to respond to variations in grid frequency (i.e. through a droop curve). Metrics for the speed of power tracking and turbine structural loads were included in the analysis of the designed controllers found in [43]. This is an important consideration, as much of the literature on APC controllers neglects the loads induced on the turbines by the control system. In order to determine structural loads induced on the turbine, simulations must be performed with a high fidelity turbine model under various operating conditions. An example of such simulations can be found in [43] which uses the FAST turbine simulation code developed by NREL [44]. It is also useful to perform field tests to validate a designed control system. The NREL National Wind Technology Center has the ability to test developed controllers on the 3-bladed Controls Advanced Research Turbine (CART3). The testing of one of the primary/secondary APC controllers found in [43] has been conducted on the CART3. The APC controller modifies CART3's actuator commands to meet the required power reference. Data from an example field test is shown in Figure 10. This experiment tests an initial control design that adjusts the maximum rotor speed to track a power reference. The second subplot in Figure 10 compares the measured and demanded output power of the turbine, and it can be observed that the control successfully tracks with the desired power reference. It would

appear that this initial design can be improved, since excessive tower load fluctuations can be observed near 600 and 925 seconds, where the controller may be tracking changes in the power reference too aggressively.

2) *AGC at the Wind Plant Level*: As was discussed in Section III, basic grid support capabilities are currently implemented on some wind plants, such as Horns Rev and Nysted. Many TSOs also require that wind plants be able to modify total active power output. Correspondingly, previous and on-going research has investigated the ability for active power control to be implemented on a plant-scale level. Simulations using simplified wind plant models have been used to verify the performance of some of these control schemes.

A significant portion of the research into implementing *AGC* with wind energy has been performed at the wind plant level and has focused on plant-wide tracking of a reference power signal to achieve an overall active power reserve. For

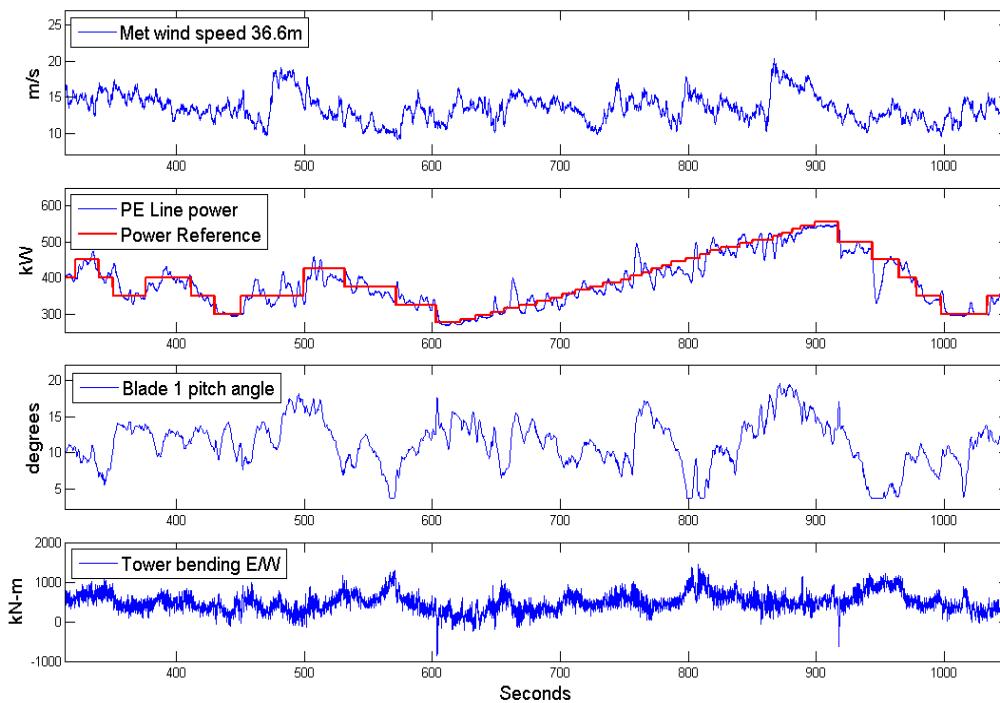

Figure 10. Field Test Data of Power Reference Tracking on CART3 Shows that sudden changes in the Power Reference Induce Increased Tower Bending Moment

Further, note how the simultaneous change of wind speed and the power reference affect the power output. Figure from [43] (reprinted with permission) example, Hansen *et al.*, [45] propose using a plant-wide *PI* control loop to distribute power reference signals to individual turbines based on a *TSO* command for overall plant active power generation. Each of the turbines uses a combined blade pitch/generator torque control strategy to track their individual power reference. Another method for wind plant active power tracking is proposed in [46]. Here, two plant scale controllers are used to respond to reference power commands by the *TSO*: a high level controller monitors mean wind speed and sets the overall plant

operating point, while a lower level controller monitors local wind effects and adjusts the operating point based on power available to each turbine. Although sophisticated methods for power reference tracking and controlling active power output of wind plants have been developed, research of control methodologies specifically for concerted inertial and primary response to deviations in grid frequency appears to be sparse.

Simulations have been used to demonstrate active power controller capabilities of wind plants, or small groups of wind turbines. In [45], simulations demonstrate the robustness of a wind plant active power control strategy as the requested operation method of the wind plant is quickly switched between maximum power, balance control, and delta control modes. Long time scale simulations, on the order of multiple hours, have been performed to demonstrate active power forecasting and reserve capabilities of a wind plant [47].

The full potential and impact of APC controls at the wind plant level calls for more advanced simulation capability. Simulation tools that include high fidelity turbine models and controls capability like NREL's FAST code, usually consider a single turbine rather than a plant. FAST includes aerodynamic modeling based on blade-element momentum theory, but this does not account for far downstream wake effects that are important in wind plant simulation. In addition, it is common practice in controls simulations that the inflow turbulence is "frozen" and does not evolve as it encounters the turbine or with downstream distance. Tools relying on frozen-wake methods are likely insufficient for simulation studies of the viability of APC at the wind plant level. An advanced simulation tool called SOWFA (Simulator for Offshore Wind Applications) allows the simulation of multiple FAST actuator line models coupled with a *CFD* (computational fluid dynamics) solver that is capable of computing an evolving turbulent inflow and wakes that propagate downstream and interact with other turbines [48]. Variations in control inputs to individual turbines will cause variations in the wakes created and propagated by the *CFD* solver. Hence, this type of tool can potentially reveal sensitivities of proposed APC schemes across an entire wind plant.

5. Conclusion

In this paper we provided an overview of modern turbine control and discussed the recent development of active power control (APC) through wind turbine control systems. As wind energy continues to reach higher penetration levels, the role of wind turbines and wind plants in grid frequency regulation is becoming more important. Several European transmission system operators in countries like Spain, Denmark and Ireland now require that new wind plants have a number of APC capabilities, including emulation of inertial frequency response and power reference tracking, with the aim of using wind plants to assist in regulation of grid frequency. The decline of grid frequency stability in the United States further motivates the implementation of APC on wind turbines. This service could be beneficial even in areas without high penetration levels, as previous research suggests, grid frequency robustness can be enhanced by even a small number of wind turbines providing frequency regulation services. Ongoing research investigates the possibility of implementing an ancillary market for these regulation capabilities, as this type of market could potentially increase the economic viability of wind energy resources. If it is possible for wind plant operators to provide the services required for grid regulation without significantly increasing fatigue damage to the turbines or other turbine costs, like *O & M*, then wind energy might be viewed as an enabling resource for grid regulation objectives, aiding in wind energy penetrations higher than 20%.

While wind turbine manufacturers have developed the capabilities to meet the requirements set by European transmission system operators, ongoing research is being performed to determine the full capabilities of wind turbine APC. Various methodologies have been presented in literature for providing the different forms of regulation (inertial, primary, and secondary); however, further research on such methodologies is necessary. Areas of interest for future research include development of controllers that achieve faster response times to changing power demands, integration of controllers designed for inertial and secondary regulation, and optimal participation by wind plants over all regulation phases. Other areas of further research include development of strategies to balance aggressive power control against increased actuator usage and structural loads, and investigation into the potential coupling of active power control loops and conventional turbine control loops. Research into these areas can be augmented by simulations that demonstrate, for instance, the ability of a controller to provide one or all of the conventional capabilities while not preventing pre-existing turbine controllers from maintaining turbine safety and minimizing fatigue and extreme loading. Ongoing research will help determine the full benefit of widespread adoption of advanced APC services provided by wind turbines.

Acknowledgements

The authors are greatly grateful to Universiti Malaysia Pahang (UMP) for the continuous support and aid.

References

- [1] "World Wind Energy Report 2010", Proc. 10th World Wind Energy Conference. Cairo, Egypt: World Wind Energy Association, (2011) November.
- [2] A. D. Hansen, "Evaluation of power control with different electrical and control concepts of wind farms", Project UpWind, Roskilde, Denmark, Tech. Rep., (2010).
- [3] R. Ele'ctrica, An Historic Challenge, (2011).
- [4] R. Wiser and M. Bolinger, "Wind Technologies Market Report", US Department of Energy, Tech. Rep., (2011).
- [5] J. F. Manwell, J. G. McGowan and A. L. Rogers, "Wind Energy Explained: Theory, Design and Application", Wiley, (2009).
- [6] H. Polinder, D.-J. Bang, H. Li and Z. Chen, "Concept for Red Ele'ctrica", Press Release. Red Ele'ctrica. Report on Generator Topologies, Mechanical and Elec- [Online]. Available: <http://www.ree.es/ingles/salaprensa/web/notasdetalle.aspx?idnota=207>tromagnetic Optimization," Project UpWind, Mekelweg, the Netherlands and Aalborg East, Denmark, Tech. Rep., (2007).
- [7] L. Greedy, "Review of Electrical Drive-train Topologies", Project UpWind, Mekelweg, the Netherlands and Aalborg East, Denmark, Tech. Rep., (2007).
- [8] J. Jonkman, S. Butterfield, W. Musial and G. Scott, "Definition of a 5-MW Reference Wind Turbine for Offshore System Development", Golden, CO: National Renewable Energy Laboratory, (2009) February.
- [9] E. Hau, "Wind turbines: fundamentals, technologies, application, economics", Springer, (2005).
- [10] K. Johnson, L. Pao, M. Balas and L. Fingersh, "Control of variable-speed wind turbines: standard and adaptive techniques for maximizing energy capture", IEEE Control Systems Magazine, vol. 26, no. 3, (2006) June, pp. 70-81.
- [11] E. Bossanyi, "Controller for 5mw reference turbine", Project UpWind, Bristol, England, Tech. Rep., (2009).
- [12] L. Vermeer, J. Sørensen and A. Crespo, "Wind Turbine Wake Aerodynamics", Progress in Aerospace Sciences, vol. 39, (2003), pp. 467-510.
- [13] B. Sanderse, "Aerodynamics of Wind Turbine Wakes", Energy Research Center of the Netherlands (ECN), ECN-E-09-016, Petten, The Netherlands, Tech. Rep., (2009).
- [14] L. Jensen, C. Mørch, P. Sørensen and K. Svendsen, "Wake Measurements from the Horns Rev Wind Farm", in Proceedings of the 2004 European Wind Energy Conference and Exhibition, London, UK, (2004).
- [15] M. Steinbuch, W. de Boer, O. Bosgra, S. Peters and J. Ploeg, "Optimal Control of Wind Power Plants", Journal of Wind Energy and Industrial Aerodynamics, vol. 27, (1988), pp. 237-246.
- [16] G. Corten and P. Schaak, "More Power and Less Loads in Wind Farms: 'Heat and Flux'", Energy Research Center of the Netherlands (ECN), ECN-RX-04-122, Petten, The Netherlands, Tech. Rep., (2004).

- [17] K. E. Johnson and N. Thomas, "Wind Farm Control: Addressing the Aerodynamic Interaction Among Wind Turbines", Proc. American Control Conf., (2009).
- [18] B. Kirby, "Frequency Regulation Basics and Trends, ORNL/TM-2004/291", Tech. Rep., (2004).
- [19] Y. Rebours, D. Kirschen, M. Trotignon and S. Rossig-nol, "A Survey of Frequency and Voltage Control Ancillary Services-Part I: Technical Features", IEEE Transactions on Power Systems, vol. 22, no. 1, (2007).
- [20] E. Ela, M. Milligan and B. Kirby, "Operating Reserves and Variable Generation", Tech. Rep., (2011).
- [21] N. W. Miller and K. Clark, "Advanced Controls Enable Wind Plants to Provide Ancillary Services", IEEE Power and Energy Society General Meeting, (2010) July.
- [22] E. Ela, "Testing Active Power Control from Wind Power at the National Wind Technology Center, NREL/PR-5500-51607", Windpower, (2011).
- [23] J. Eto, "Use of Frequency Response Metrics to Assess the Planning and Operating Requirements for Reliable Integration of Variable Renewable Generation. Lawrence Berkeley National Laboratory: Lawrence Berkeley National Laboratory. LBNL Paper LBNL-4142E", (2011). [Online]. Available: <http://escholarship.org/uc/item/0kt109pn>.
- [24] R. Wiser, Z. Yang, M. Hand, O. Hohmeyer, D. Infield, P. H. Jensen, V. Nikolaev, M. O'Malley and G. S. A. Zervos, "IPCC Special Report on Renewable Energy Sources and Climate Change Mitigation: Wind Energy", IPCC, Cambridge, UK and New York, NY, USA, Tech. Rep., (2011). [Online]. Available: <http://srren.ipcc-wg3.de/report>.
- [25] I. Margaritis, "Power system requirements for high wind penetration", Project UpWind, Roskilde, Denmark, Tech. Rep., (2007).
- [26] "Wind Farm Transmission Grid Code Provisions: A Direction by the Commission for Energy Regulation," Commission for Energy Regulation, Dublin, Ireland, Tech. Rep., (2004).
- [27] "Wind Turbines Connected to Grids with Voltages Above 100kV: Technical regulation for the properties and the regulation for wind turbines", Elkraft System and Eltra, Erritsø, Denmark, Tech. Rep., (2003).
- [28] "Technical Requirements for the Connection of Generation Facilities to the Hydro-Quebec Transmission System: Supplementary Requirements for Wind Generation," Hydro-Quebec, Montreal, Quebec, Canada, Tech. Rep., (2005).
- [29] "Technical Requirements for Wind Power and Photovoltaic Installations and Any Generating Facilities Whose Technology Does Not Consist of a Synchronous Generator Directly Connected to the Grid", Red Eléctrica, Madrid, Spain, Tech. Rep., (2008).
- [30] B. Kirby, M. Milligan and E. Ela, "Providing Minute-to-Minute Regulation from Wind Plants", 9th Annual International Workshop on Large-Scale Integration of Wind Power into Power Systems and Transmission Networks for Offshore Wind Power Plants, Quebec, Canada, (2010).
- [31] R. J. Nelson, "Frequency-responsive wind turbine output control", U.S. Patent 0 001 318, (2011) January 6.
- [32] A. Yasugi, "Wind turbine generator and method of controlling the same", U.S. Patent 0 074 152, (2011) March 31.
- [33] A. Nyborg and S. Dalsgaard, "Power curtailment of wind turbines", U.S. Patent 0 286 835, (2011) November 11.
- [34] J. A. Sanchez, A. C. Mayor, J. M. Lusarreta, J. P. Barbachano, S. S. Segura, D. S. Lopez, M. Z. Maeztu, L. M. Palomo and J. L. Taberna, "Method of operation of a wind turbine to guarantee primary or secondary regulation in an electric grid", U.S. Patent 0 057 445, (2011) March 10.
- [35] H. Ichinose and T. Wakasa, "Wind-turbine-generator control system, wind farm, and wind-turbine-generator control method", U.S. Patent 0 057 445, (2011) August 4.
- [36] J. Mayor, D. Sole, J. Acedo, A. Carcar, J. Barbachano, M. Zabaleta and S. Simon, "Control of active power reserve in a wind-farm", U.S. Patent 0 055 030, (2009) February 26.
- [37] M. A. Morjaria and M. A. Shah, "Intelligent active power management system for renewable variable power generation", U.S. Patent 0 144 816, (2011) June 16.
- [38] P. Keung, P. Li, H. Banakar and B. Ooi, "Kinetic Energy of Wind-Turbine Generators for System Frequency Support", IEEE Transactions on Power Systems, vol. 24, no. 1, (2009) February.
- [39] I. Erlich and M. Wilch, "Primary Frequency Control by Wind Turbines", IEEE Power and Energy Society General Meeting, (2010) July.
- [40] H. Ma and B. Chowdhury, "Working Towards Frequency Regulation with Wind Plants: Combined Control Approaches", Renewable Power Generation", IET, vol. 4, no. 4, (2010) July, pp. 308–316.
- [41] X. Juankorena, I. Esandi, J. Lopez and L. Marroyo, "Method to Enable Variable Speed Wind Turbine Primary Regulation", International Conference on Power Engineering, Energy and Electrical Drives, (2009) March.
- [42] R. de Almeida and J. P. Lopes, "Participation of Doubly Fed Induction Wind Generators in System Frequency Regulation", IEEE Transactions on Power Systems, vol. 22, (2007), pp. 944–950.
- [43] Y. Jeong, "Comparison and Testing of Active Power Control Strategies for Grid-connected Wind Turbines", Master's thesis, Colorado School of Mines, (2011).

- [44] J. Jonkman and M. L. Buhl, "FAST User's Guide", Golden, CO: National Renewable Energy Laboratory, **(2005)**.
- [45] A. Hansen, P. Sørensen, F. Iov and F. Blaabjerg, "Centralised Power Control of Wind Farm with Doubly Fed Induction Generators", *Renewable Energy*, vol. 31, **(2006)**, pp. 935-951.
- [46] V. Spudic, M. Jelavic, M. Baotic and N. Peric, "Hi-erarchical Wind Farm Control for Power-Load Optimization", *The Science of making Torque from Wind*, **(2010)**.
- [47] A. Gesino, "Power reserve provision with wind farms," Ph.D. dissertation, University of Kassel, **(2010)**.
- [48] M. Churchfield and S. Lee. NWTC design codes- SOWFA. [Online]. Available: <http://wind.nrel.gov/designcodes/simulators/sowfare>, **(2012)**.

